

waste water and sewage pumps

dp pumps

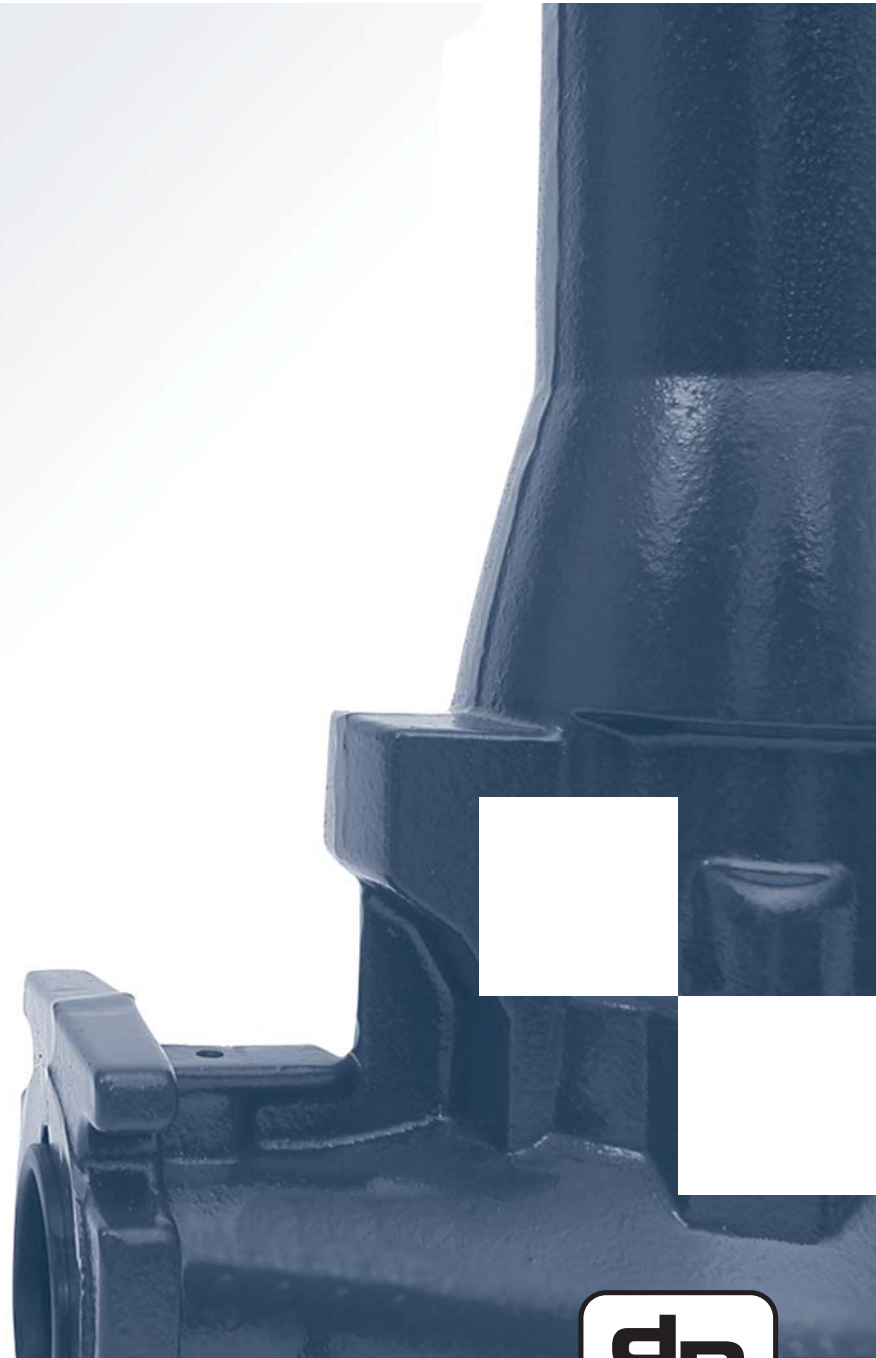

■ technical data



Experience water on a different level

For every application The right high tech solution

INDEX

<i>General information</i>	02
<i>Selection charts</i>	04
<i>Pump characteristics</i>	06
<i>Model identification</i>	07
<i>DVV 3 / DVV 4</i>	08
<i>DVV 7</i>	10
<i>DVV 7 VD</i>	12
<i>DVV 7 K</i>	14
<i>DVV 10</i>	16
<i>DVV 27</i>	18
<i>DRV 6</i>	20
<i>DRV 8</i>	22
<i>DRV 9</i>	24
<i>DRV 11</i>	26
<i>DRV 12</i>	28
<i>DRV 13</i>	30
<i>DRV 24</i>	32
<i>DRV 27</i>	34
<i>DRSK 21</i>	36
<i>DRSK 31</i>	38
<i>DRS 3</i>	40
<i>DRS 4</i>	42
<i>DRS 6</i>	44
<i>DRK 23</i>	46
<i>DRK 41</i>	48
<i>DRK 87</i>	50
<i>DRK 107</i>	52
<i>DRK 145</i>	54
<i>DRK 178</i>	56
<i>DRK 220</i>	58
<i>DRK 250</i>	60
<i>FEKA UNIT</i>	62
<i>Accessories</i>	64
<i>Notes</i>	65

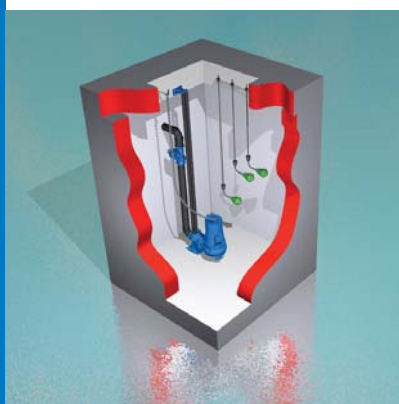

- In the Dutch market DP-Pumps has years of experience to build on when it comes to water management/ the transport of water in the broadest sense of the word: we are just as skilful at treating wastewater as we are at boosting drinking water, the business we once began with. Whether it concerns waste water or sewage: we control the dynamics of water in both segments. That's why we are now also offering our expertise on waste water to our customers abroad.

Treatment of waste water, a serious task

A correct treatment of waste water is just as important as the treatment of drinking water. The variety of pumps and the numerous projects in the Netherlands, prove that we take the treatment of waste water very seriously. All of our pumps, irrespective of the type, contribute to the simple, but most of all the reliable control of waste water. Safety and environment are special points of interest: all of our waste water and sewage pumps meet the highest safety and environmental requirements.

A world of possibilities

Waste water is an extensive concept. That is why we offer you a wide delivery program with pumps that are applicable in many sectors. DP-Pumps offers pumps for the drainage of waste water in the industry or in the domestic situation.

The possibilities for the processing of sewage are just as wide. Our sewage (submersible) pumps with free-flow impeller, single-vane impeller, non-clogging impeller or



DP-Pumps is an ISO-9001 and ISO-14001 certified company.



management



cutter are available in different designs and capacities. All of them guaranteeing the high reliability DP-Pumps stands for.

Personal advice

Our area managers and technical advisors will be glad to assist you in managing the dynamics of (waste) water. Please feel free to contact us whenever you have questions or need more information regarding the possibilities of our products.

SELECTION CHARTS

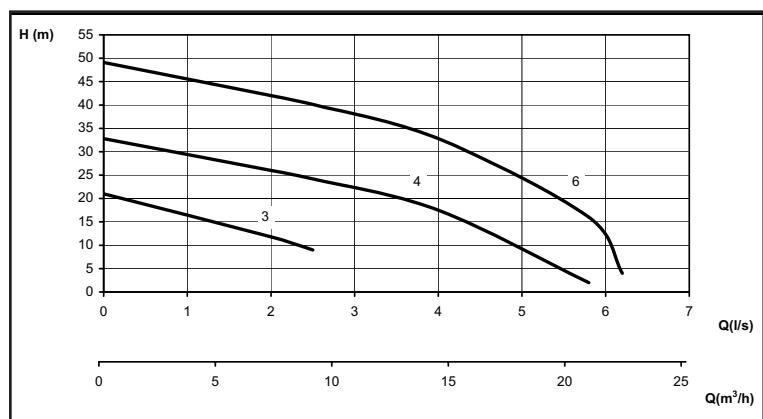
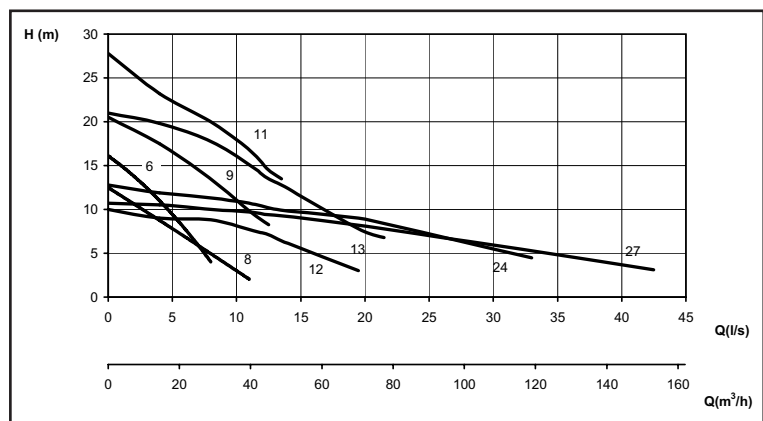
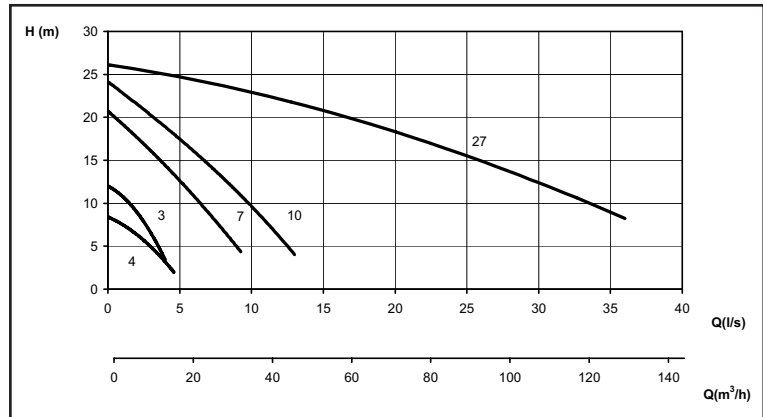

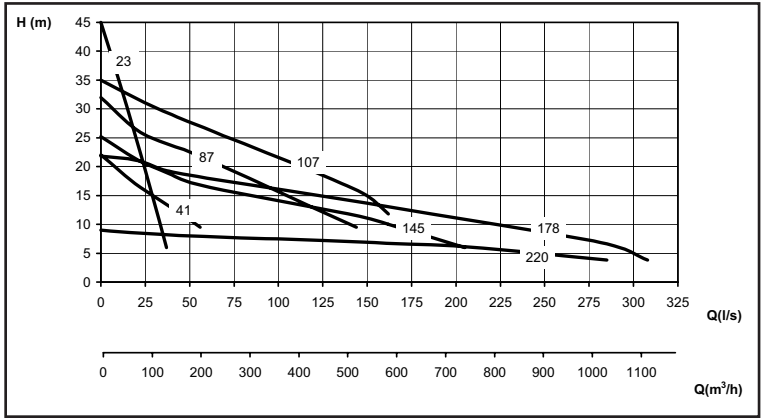

DRK

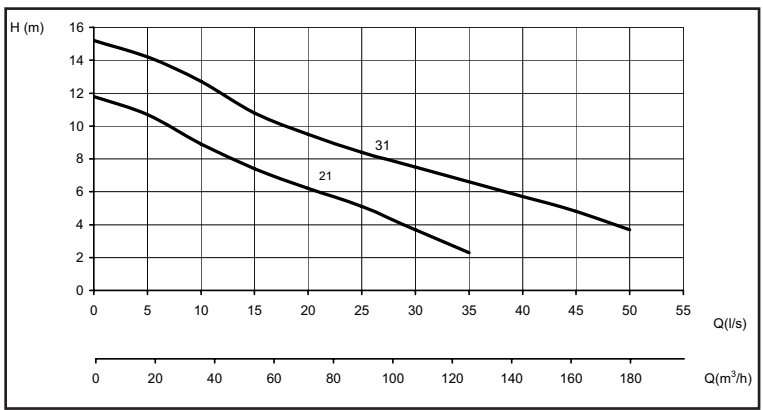

DRSK

PUMP CHARACTERISTICS

V impeller

Free flow impeller for fluids containing larger solid and long fibrous stringy material or coarse solids, as well as fluids with entrapped air or gas.

- Raw waste water
- Activated sludge
- Circulated and heating sludge
- Raw and digested sludge
- Mixed water



S impeller

Cutter for domestic sewage water containing fibrous stringy material.

- Domestic waste water
- Raw water
- Faeces



K impeller

Single- vane impeller for waste water containing solid and fibrous stringy material.

- Raw and waste water
- Mixed water
- Raw and digested sludge
- Activated sludge
- Circulated and heating sludge



SK impeller

Non-clogging impeller for waste water containing solid and fibrous stringy material or coarse solids.

- Raw and waste water
- Mixed water
- Raw and digested sludge
- Activated sludge
- Circulated and heating sludge



MODEL IDENTIFICATION

DVV 711-2WS	D	V	V	7	11	- 2	W	S		
DRV 2426-4 165 E	D	R	V	24	26	- 4			165	E
D: DP-Pumps										
V: Waste water										
R: Sewage water										
V: Free-flow impeller										
S: Cutter										
K: Vane impeller										
SK: Non-clogging impeller										
Nominal capacity in l/sec.										
Motor rating (P2) in kW (kW *10 > 1,1=11)										
Motor size 2-pole : 2850 min ⁻¹ 4-pole : 1425 min ⁻¹										
1~ motor										
Level control S: float switch A: automatic switch (Intelligent Control System)										
Impeller diameter [mm]										
Special models O: oil resistant IN: industry K: cooling jacket E: flame proof HT: high temperature VD: enlarged free passage										

DVV 3 DVV 4

Flange [PN]	2,5
Pump casing	PP-H
Shaft seal pump side	2x seal ring
Shaft seal motor side	seal ring
Elastomer components	NBR
Connect Voltage [V]	1 * 230
Motor Voltage [V]	1 * 230
IP	68
Insulation Class	F
Thermal Motor Monitoring	Clixon
Electric connection	Cable+plug
Nom. speed [min-1]	2850
Temp. Max pumped liquid [°C]	35

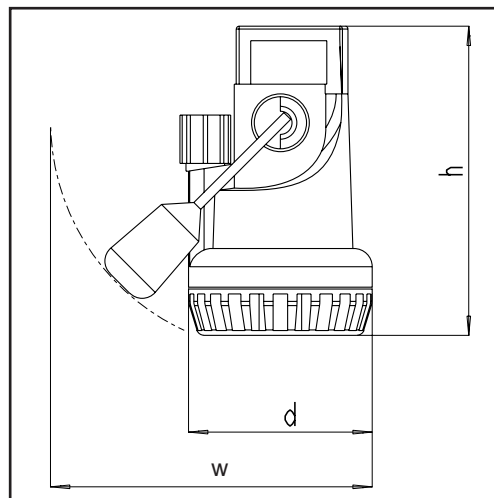

Pump type	Connection [G]/[DN]	Impeller	Shaft	P2 [kW]	Rated current [A]	Electric cable n x [mm ²]	Length electric cable [m]	Free passage [mm]	h x w x d [mm]	Pump control	Weight [kg]
32 W(S)	5/4	PP	1.4021	0,15	1,40	3 x 1	10	10	321 x 332 x 190	No	5
32 WS	5/4	PP	1.4021	0,15	1,40	3 x 0,75	3	10	321 x 332 x 190	Floatswitch rod	4
34 W(S)	5/4	PPO	1.4021	0,40	3,60	3 x 1	10	10	375 x 332 x 190	No	7
34 WS	5/4	PPO	1.4021	0,40	3,60	3 x 0,75	3	10	375 x 332 x 190	Floatswitch rod	6
34 WS VD	5/4	PP	1.4028	0,40	2,80	3 x 1	10	24	410 x 395 x 190	Floatswitch rod	6,7
43 WS	6/4	PA	1.4028	0,30	2,80	3 x 1	10	35	420 x 395 x 285	Floatswitch rod	7,1
44 WS	6/4	PA	1.4028	0,40	3,60	3 x 1	10	35	420 x 395 x 285	Floatswitch rod	7,1

Special versions

'IN' version for more abrasive water such as salty, swimming pool or brackish water

- Motor housing Stainless Steel 1.4571 instead of Stainless Steel 1.4301
- Motor shaft Stainless Steel 1.4571 instead of chrome steel
- Medium temperature max. 40 °C in stead of 35 °C



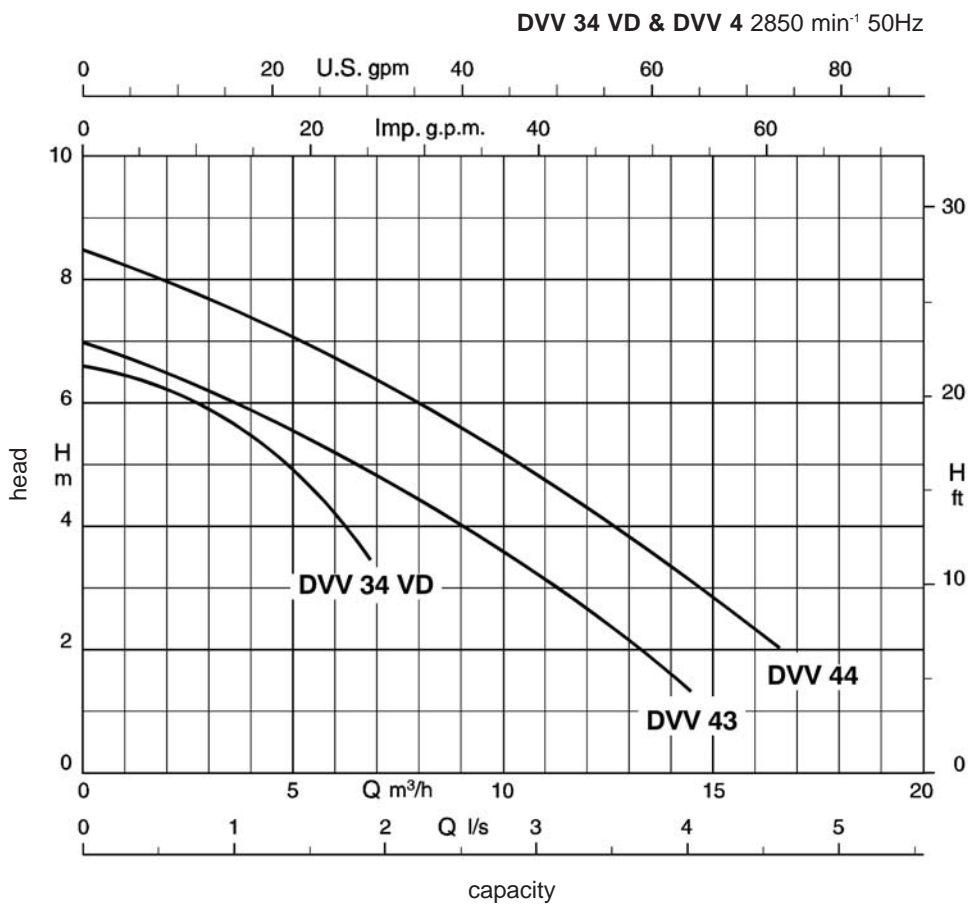
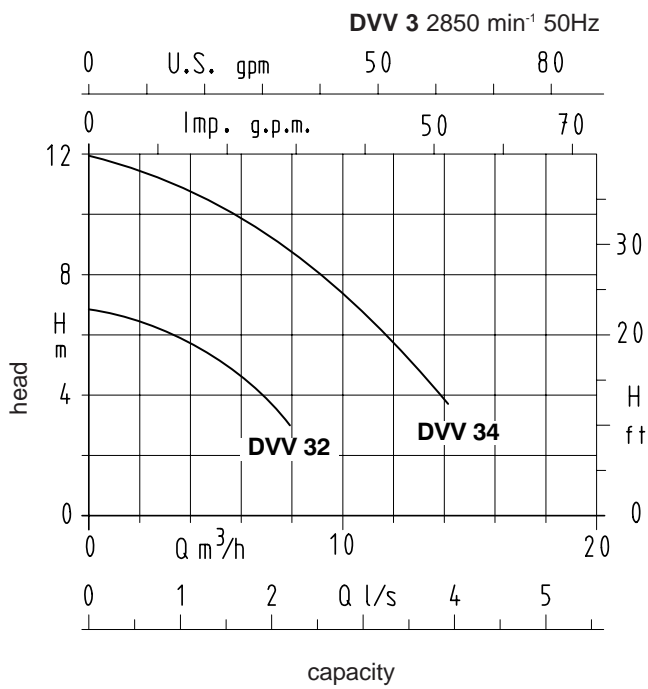

DVV 7

Connection [G]/[DN]	6/4
Flange [PN]	2,5
Pump Casing	1.4301
Impeller	PA
Shaft	1.4021
Shaft seal pump side	SiC/SiC
Shaft seal motor side	seal ring
Elastomer components	NBR
IP	68
Insulation Class	F
Length electric cable [m]	10
Nom. speed [min ⁻¹]	2850
Free passage [mm]	10
h x w x d [mm]	440 x 300 x 280
Temp. Max pumped liquid [°C]	40

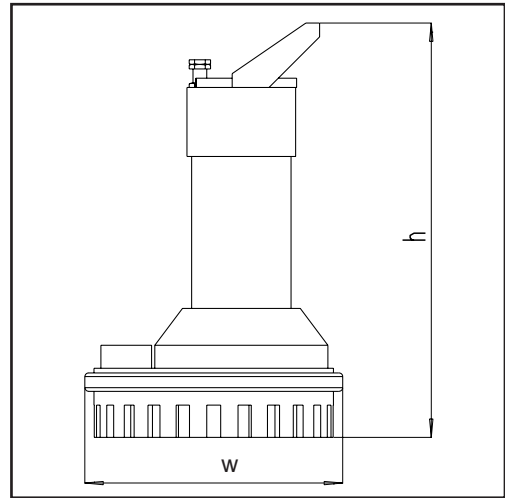

Pump type	P2 [kW]	Rated current [A]	Connect Voltage [V]	Motor Voltage [V]	Thermal Motor Monitoring	Electric cable n x [mm ²]	Electric connection	Pump control	Weight [kg]
76	0,55	1,70	3 * 400	3 * 400	Bi-metal	6 x 1	Cable	No	13,3
76 S	0,55	1,70	3 * 400	3 * 400	Bi-metal	6 x 1	Cable+plug	Floatswitch	15,1
76 W	0,55	4,10	1 * 230	1 * 230	Clixon	3 x 1	Cable+plug	No	12,2
76 WS	0,55	4,10	1 * 230	1 * 230	Clixon	3 x 1	Cable+plug	Floatswitch	12,7
78	0,75	1,90	3 * 400	3 * 400	Bi-metal	6 x 1	Cable	No	13,3
78 S	0,75	1,90	3 * 400	3 * 400	Bi-metal	6 x 1	Cable+plug	Floatswitch	15,1
78 W	0,75	5,50	1 * 230	1 * 230	Clixon	3 x 1	Cable+plug	No	12,2
78 WS	0,75	5,50	1 * 230	1 * 230	Clixon	3 x 1	Cable+plug	Floatswitch	12,7
711	1,10	2,50	3 * 400	3 * 400	Bi-metal	6 x 1	Cable	No	13,3
711 S	1,10	2,50	3 * 400	3 * 400	Bi-metal	6 x 1	Cable+plug	Floatswitch	15,1
711 W	1,10	6,55	1 * 230	1 * 230	Clixon	3 x 1	Cable+plug	No	14,5
711 WS	1,10	6,55	1 * 230	1 * 230	Clixon	3 x 1	Cable+plug	Floatswitch	15
715	1,50	3,60	3 * 400	3 * 400	Bi-metal	6 x 1	Cable	No	15,6
715 S	1,50	3,60	3 * 400	3 * 400	Bi-metal	6 x 1	Cable+plug	Floatswitch	17,5
715 W	1,50	8,95	1 * 230	1 * 230	Clixon	3 x 1	Cable+plug	No	14,5
715 WS	1,50	8,95	1 * 230	1 * 230	Clixon	3 x 1	Cable+plug	Floatswitch	15
722	2,20	4,80	3 * 400	3 * 400	Bi-metal	6 x 1	Cable	No	15,7
722 S	2,20	4,80	3 * 400	3 * 400	Bi-metal	6 x 1	Cable+plug	Floatswitch	17,6



DVV 7 2850 min⁻¹ 50Hz

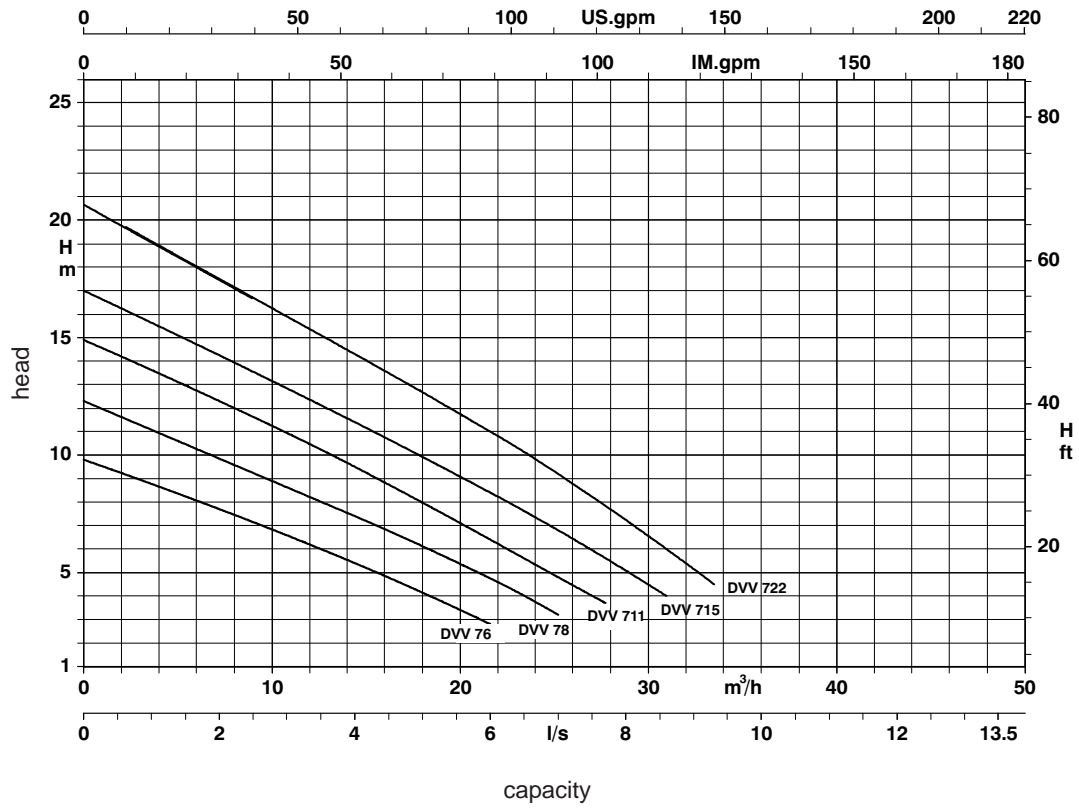

DVV 7 VD

Connection [G]/[DN]	6/4
Flange [PN]	2,5
Pump casing	1.4301
Impeller	PA
Shaft	1.4021
Shaft seal pump side	SiC/SiC
Shaft seal motor side	seal ring
Elastomer components	NBR
IP	68
Insulation Class	F
Length electric cable [m]	10
Nom. speed [min ⁻¹]	2850
Free passage [mm]	35
h x w x d [mm]	500 x 300 x 280
Temp. Max pumped liquid [°C]	40

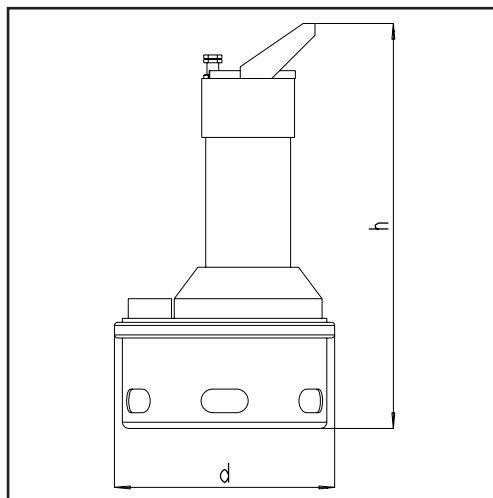

Pump type	P2 [kW]	Rated current [A]	Connect Voltage [V]	Motor Voltage [V]	Thermal Motor Monitoring	Electric cable n x [mm ²]	Electric connection	Pump control	Weight [kg]
76 VD	0,55	1,70	3 * 400	3 * 400	Bi-metal	6 x 1	Cable	No	14,4
76 S VD	0,55	1,70	3 * 400	3 * 400	Bi-metal	6 x 1	Cable+plug	Floatswitch	16,1
76 W VD	0,55	4,10	1 * 230	1 * 230	Clixon	3 x 1	Cable+plug	No	13,2
76 WS VD	0,55	4,10	1 * 230	1 * 230	Clixon	3 x 1	Cable+plug	Floatswitch	13,7
711 VD	1,10	2,50	3 * 400	3 * 400	Bi-metal	6 x 1	Cable	No	14,4
711 S VD	1,10	2,50	3 * 400	3 * 400	Bi-metal	6 x 1	Cable+plug	Floatswitch	16,1
711 W VD	1,10	6,55	1 * 230	1 * 230	Clixon	3 x 1	Cable+plug	No	15,5
711 WS VD	1,10	6,55	1 * 230	1 * 230	Clixon	3 x 1	Cable+plug	Floatswitch	16
722 VD	2,20	4,80	3 * 400	3 * 400	Bi-metal	6 x 1	Cable	No	16,9
722 S VD	2,20	4,80	3 * 400	3 * 400	Bi-metal	6 x 1	Cable+plug	Floatswitch	18,7

Special version

'IN' version with stainless steel 1.4401 instead of stainless steel 1.4301 suitable for more abrasive water such as salty, swimming pool or brackish water



DVV 7 VD 2850 min⁻¹ 50Hz

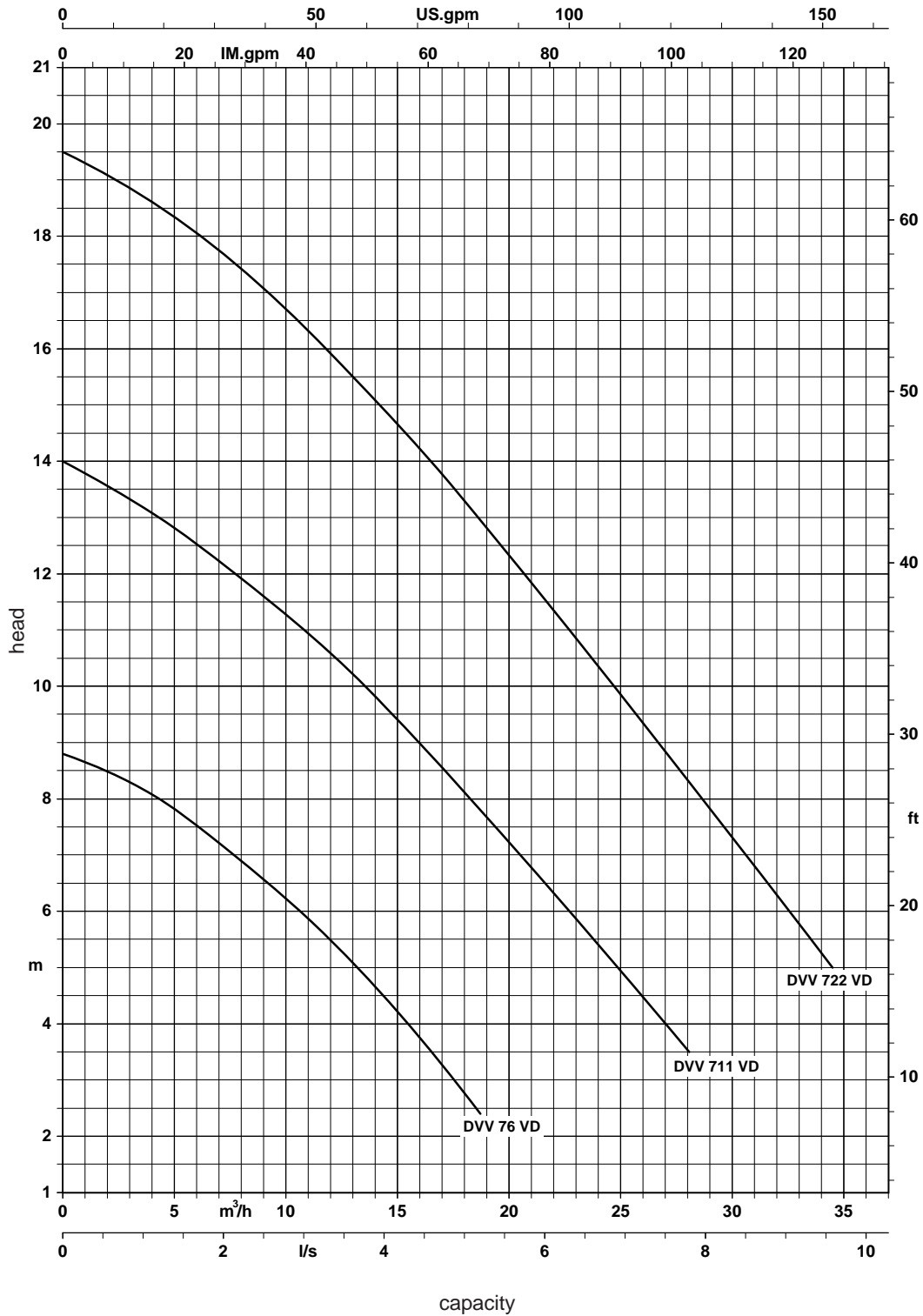

DVV 7 K

Connection [G]/[DN]	2
Flange [PN]	2,5
Pump casing	1.4301
Impeller	PA
Shaft	1.4021
Shaft seal pump side	SiC/SiC
Shaft seal motor side	seal ring
Elastomer components	NBR
IP	68
Insulation Class	F
Length electric cable [m]	10
Nom. speed [min ⁻¹]	2850
Free passage [mm]	10
h x w x d [mm]	440 x 300 x 280
Temp. Max pumped liquid [°C]	40

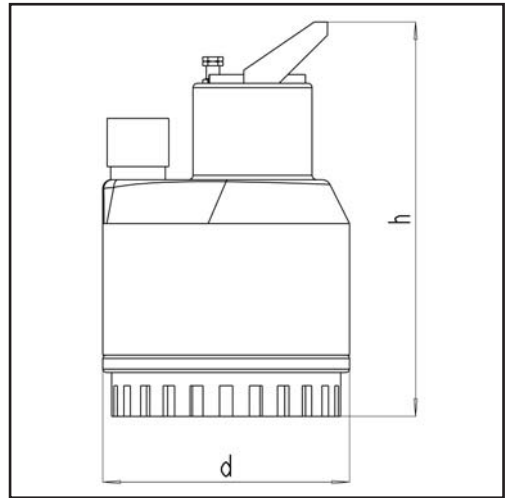

Pump type	P2 [kW]	Rated current [A]	Connect Voltage [V]	Motor Voltage [V]	Thermal Motor Monitoring	Electric cable n x [mm ²]	Electric connection	Pump control	Weight [kg]
76 K	0,55	1,70	3 * 400	3 * 400	Bi-metal	6 x 1	Cable	No	15,3
76 S K	0,55	1,70	3 * 400	3 * 400	Bi-metal	6 x 1	Cable+plug	Floatswitch	17,1
76 W K	0,55	4,10	1 * 230	1 * 230	Clixon	3 x 1	Cable+plug	No	14,2
76 WS K	0,55	4,10	1 * 230	1 * 230	Clixon	3 x 1	Cable+plug	Floatswitch	14,7
78 K	0,75	1,90	3 * 400	3 * 400	Bi-metal	6 x 1	Cable	No	15,3
78 S K	0,75	1,90	3 * 400	3 * 400	Bi-metal	6 x 1	Cable+plug	Floatswitch	17,1
78 W K	0,75	5,50	1 * 230	1 * 230	Clixon	3 x 1	Cable+plug	No	14,2
78 WS K	0,75	5,50	1 * 230	1 * 230	Clixon	3 x 1	Cable+plug	Floatswitch	14,7
711 K	1,10	2,50	3 * 400	3 * 400	Bi-metal	6 x 1	Cable	No	15,3
711 S K	1,10	2,50	3 * 400	3 * 400	Bi-metal	6 x 1	Cable+plug	Floatswitch	17,1
711 W K	1,10	6,55	1 * 230	1 * 230	Clixon	3 x 1	Cable+plug	No	16,5
711 WS K	1,10	6,55	1 * 230	1 * 230	Clixon	3 x 1	Cable+plug	Floatswitch	17
715 K	1,50	3,60	3 * 400	3 * 400	Bi-metal	6 x 1	Cable	No	17,6
715 S K	1,50	3,60	3 * 400	3 * 400	Bi-metal	6 x 1	Cable+plug	Floatswitch	19,5
715 W K	1,50	8,95	1 * 230	1 * 230	Clixon	3 x 1	Cable+plug	No	16,5
715 WS K	1,50	8,95	1 * 230	1 * 230	Clixon	3 x 1	Cable+plug	Floatswitch	17
722 K	2,20	4,80	3 * 400	3 * 400	Bi-metal	6 x 1	Cable	No	17,7
722 S K	2,20	4,80	3 * 400	3 * 400	Bi-metal	6 x 1	Cable+plug	Floatswitch	19,6

Special versions

'IN' version with stainless steel 1.4401 in stead of stainless steel 1.4301 suitable for more abrasive water such as salty, swimming pool or brackish water

'O' version suitable for pumping water containing oil. Elastomers in Viton.



DVV 7 K 2850 min⁻¹ 50Hz

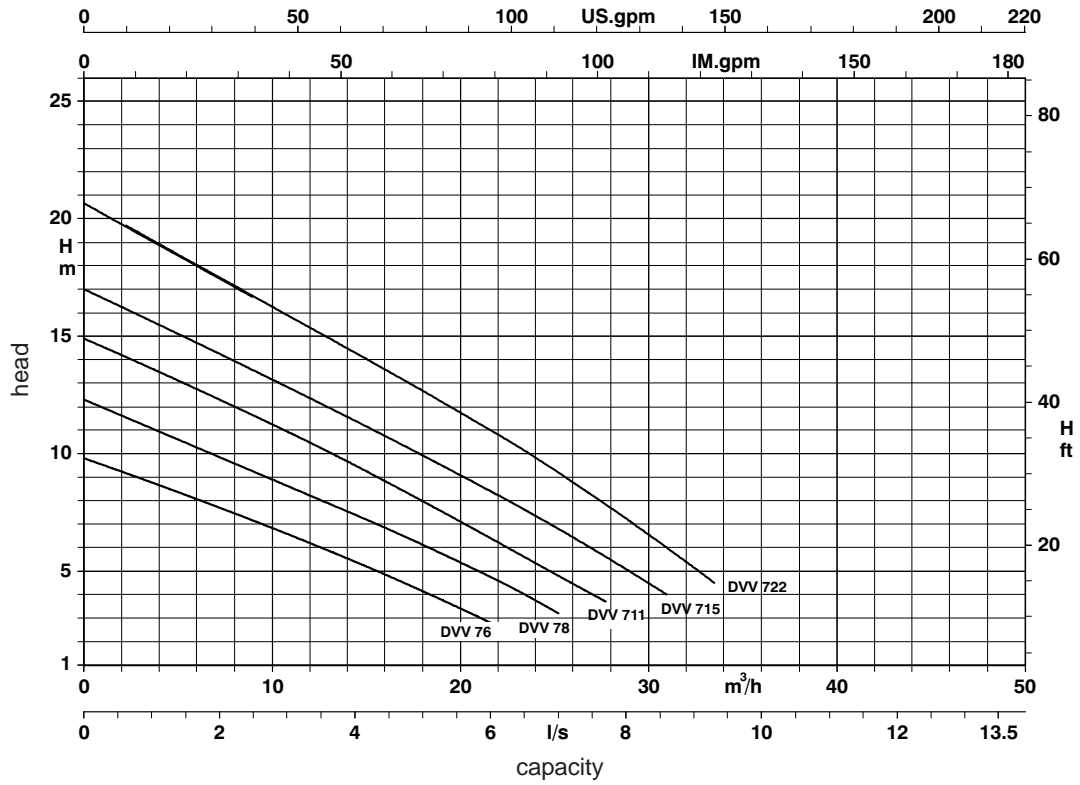

DVV 10

Connection [G]/[DN]	2
Flange [PN]	2,5
Pump casing	JL 1040
Impeller	PA
Shaft	1.4021
Shaft seal pump side	SiC/SiC
Shaft seal motor side	seal ring
Elastomer components	NBR
P2 [kW]	2,20
Rated current [A]	4,80
Connect Voltage [V]	3 * 400
Motor Voltage [V]	3 * 400
IP	68
Insulation Class	F
Thermal Motor Monitoring	Bi-metal
Electric cable n x [mm ²]	6 x 1
Length electric cable [m]	10
Nom. speed [min-1]	2850
Free passage [mm]	11
h x w x d [mm]	480 x 340 x 240
Temp. Max pumped liquid [°C]	40

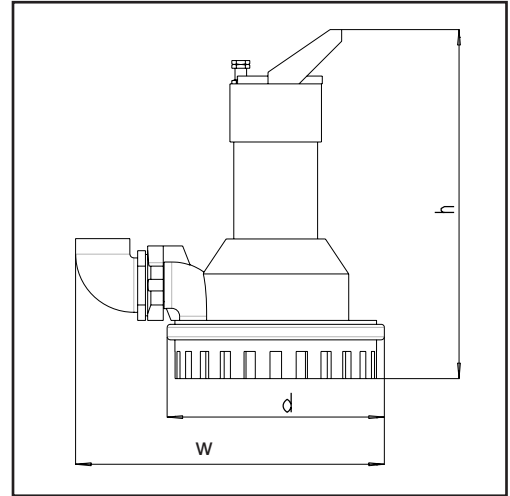

Pump type	Electric connection	Pump control	Weight [kg]
1022	Cable	No	22,5
1022 S	Cable+plug	Floatswitch	24,5



DVV 10 2850 min⁻¹ 50Hz

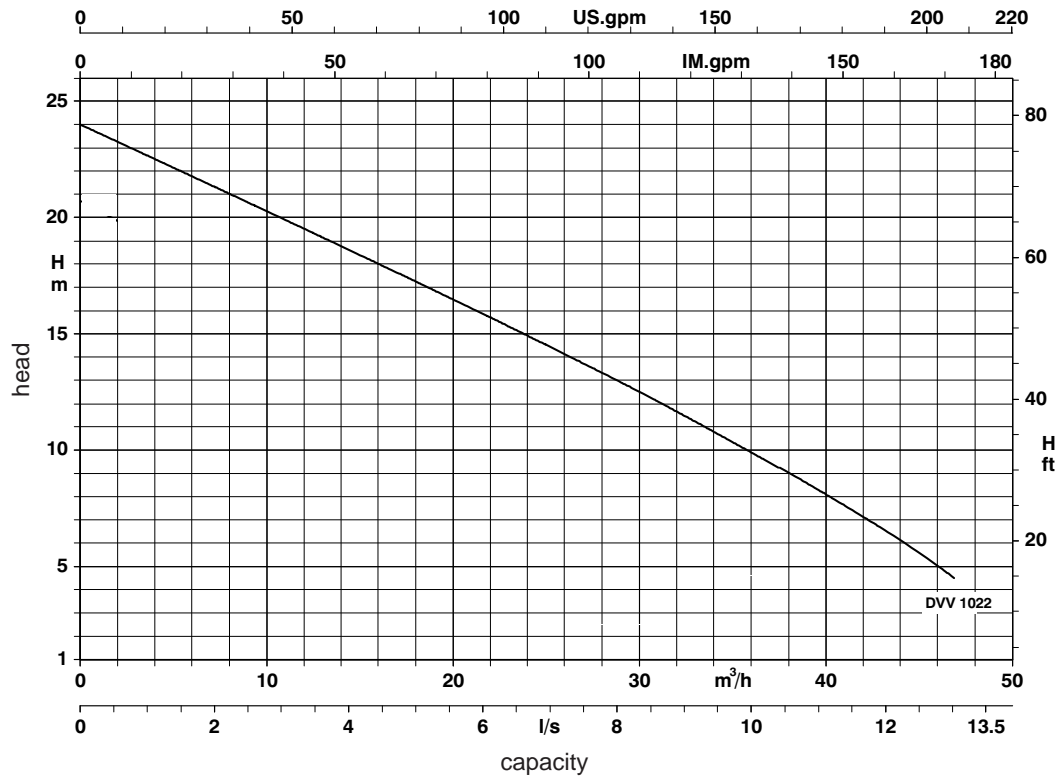

DVV 27

Flange [PN]	16
Pump Casing	GG
Impeller	cast iron
Shaft	1.4021
Shaft seal pump side	TuC/TuC
Shaft seal motor sid	TuC/TuC
Elastomer components	NBR
Connect Voltage [V]	3 * 400
IP	68
Isulation Class	F
Thermal Motor Monitoring	Bi-metal
Length electric cable [m]	10
Nom. speed [min-1]	2850
Free passage [mm]	12
Temp. Max pumped liquid [°C]	50

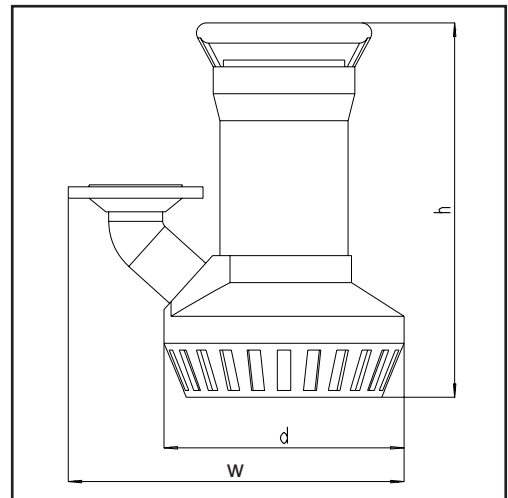

Pump type	Connection [G]/[DN]	P2 [kW]	Rated current [A]	Motor Voltage [V]	Electric cable n x [mm ²]	Electric connection	h x w x d [mm]	Pump control	Weight [kg]
2740	80	4,00	8,50	3 * 400	7 x 1,5	Cable+plug	556 x 511 x 356	No	60,5
2740 S	80	4,00	8,50	3 * 400	7 x 1,5	Cable+plug	556 x 511 x 356	Floatswitch	61
2775	100	7,50	15,40	400/692	11 x 1,5	Cable	628 x 578 x 416	No	94,5
2775 S	100	7,50	15,40	400/692	11 x 1,5	Cable	628 x 578 x 416	Floatswitch	96

Special version

'IN' version for liquids containing sand

Material pump casing: rubber-lined cast iron

Impeller option: Norihard



DVV 27 2850 min⁻¹ 50Hz

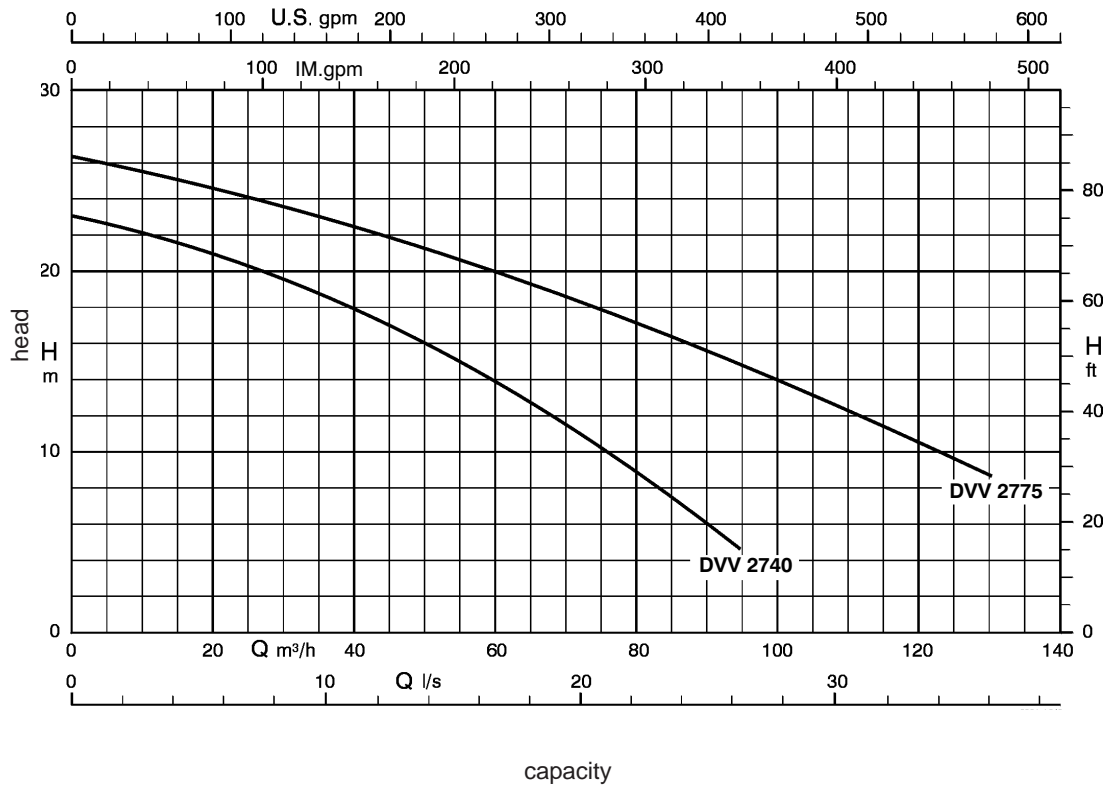

DRV 6

Connection [G]/[DN]	50
Flange [PN]	6
Pump Casing	JL 1030
Impeller	JL 1030
Shaft	1.4021
Shaft seal pump side	SiC/Ce
Shaft seal motor side	seal ring
Elastomer components	NBR
IP	68
Isulation Class	F
Length electric cable [m]	10
Nom. speed [min-1]	2850
Temp. Max pumped liquid [°C]	40
Weight [kg]	22

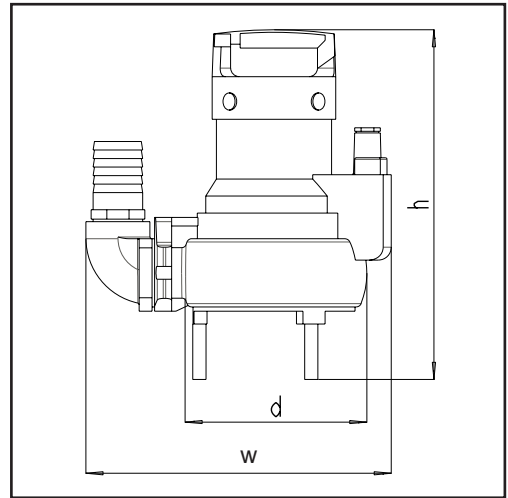

Pump type	P2 [kW]	Rated current [A]	Connect Voltage [V]	Motor Voltage [V]	Thermal Motor Monitoring	Electric cable n x [mm ²]	Electric connection	Impeller diam. [mm]	Free passage [mm]	h x w x d [mm]	Pump control
66-2 100	0,55	5,00	3 * 400	3 * 400	~	4 x 1	Cable	100	45	396 x 318 x 198	No
66-2A 100	0,55	2,30	3 * 400	3 * 400	~	4 x 1	Cable	100	45	398 x 328 x 198	Autom
66-2W 100	0,55	5,00	1 * 230	1 * 230	Clixon	3 x 1	Cable+plug	100	45	396 x 318 x 198	No
66-2WA 100	0,55	5,00	1 * 230	1 * 230	Clixon	3 x 1	Cable+plug	100	45	398 x 328 x 198	Autom
66-2WS 100	0,55	5,00	1 * 230	1 * 230	Clixon	3 x 1	Cable+plug	100	45	396 x 318 x 198	Floatswitch
68-2 110	0,75	2,80	3 * 400	3 * 400	~	4 x 1	Cable	110	45	396 x 318 x 198	No
68-2A 110	0,75	2,80	3 * 400	3 * 400	~	4 x 1	Cable	110	45	398 x 328 x 198	Autom
68-2W 110	0,75	6,00	1 * 230	1 * 230	Clixon	3 x 1	Cable+plug	110	45	396 x 318 x 198	No
68-2WA 110	0,75	6,00	1 * 230	1 * 230	Clixon	3 x 1	Cable+plug	110	45	398 x 328 x 198	Autom
68-2WS 110	0,75	6,00	1 * 230	1 * 230	Clixon	3 x 1	Cable+plug	110	45	396 x 318 x 198	Floatswitch
611-2 120	1,10	3,00	3 * 400	3 * 400	~	4 x 1	Cable	120	43	396 x 318 x 198	No
611-2A 120	1,10	3,00	3 * 400	3 * 400	~	4 x 1	Cable	120	43	398 x 328 x 198	Autom
611-2W 120	1,10	8,20	1 * 230	1 * 230	Clixon	3 x 1	Cable+plug	120	43	396 x 318 x 198	No
611-2W 130	1,10	8,20	1 * 230	1 * 230	Clixon	3 x 1	Cable+plug	130	41	396 x 318 x 198	No
611-2WA 120	1,10	8,20	1 * 230	1 * 230	Clixon	3 x 1	Cable+plug	120	43	398 x 328 x 198	Autom
611-2WA 130	1,10	8,20	1 * 230	1 * 230	Clixon	3 x 1	Cable+plug	130	41	398 x 328 x 198	Autom
611-2WS 120	1,10	8,20	1 * 230	1 * 230	Clixon	3 x 1	Cable+plug	120	43	396 x 318 x 198	Floatswitch
611-2WS 130	1,10	8,20	1 * 230	1 * 230	Clixon	3 x 1	Cable+plug	130	41	396 x 318 x 198	Floatswitch
615-2 130	1,50	3,50	3 * 400	3 * 400	~	4 x 1	Cable	130	41	396 x 318 x 198	No
615-2A 130	1,50	3,50	3 * 400	3 * 400	~	4 x 1	Cable	130	41	398 x 328 x 198	Autom



DRV 6 2850 min⁻¹ 50Hz

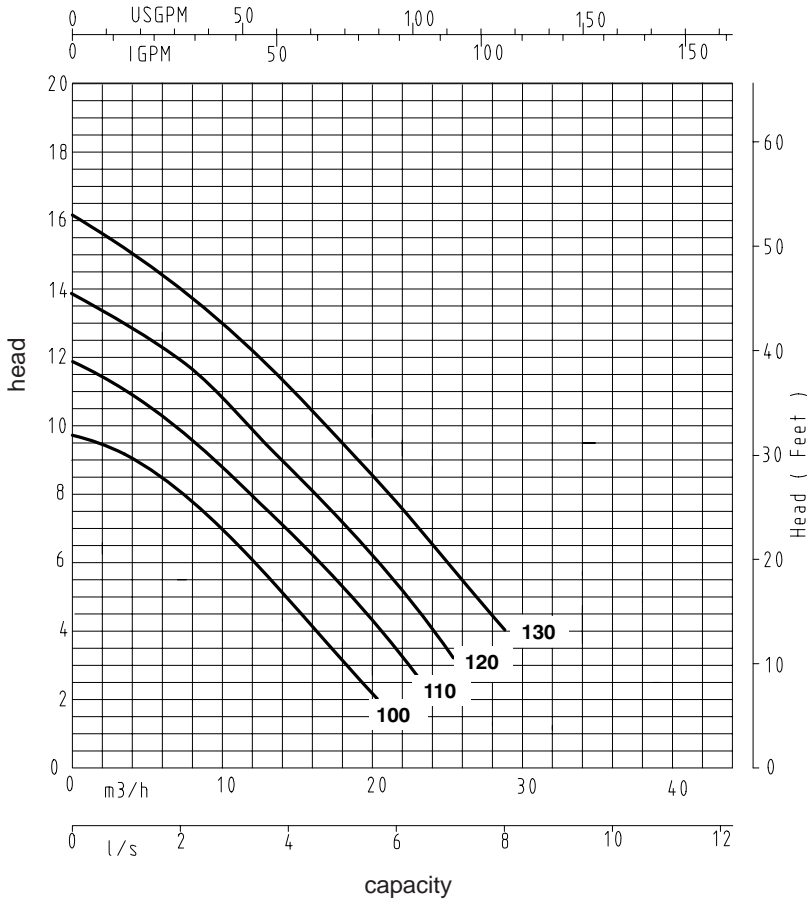

DRV 8

Connection [G]/[DN]	65
Flange [PN]	16
Pump Casing	JL 1030
Impeller	JL 1030
Shaft	1.4021
Shaft seal pump side	SiC/Ce
Shaft seal motor side	seal ring
Elastomer components	NBR
IP	68
Insulation Class	F
Length electric cable [m]	10
Nom. speed [min ⁻¹]	2850
Temp. Max pumped liquid [°C]	40
Weight [kg]	25

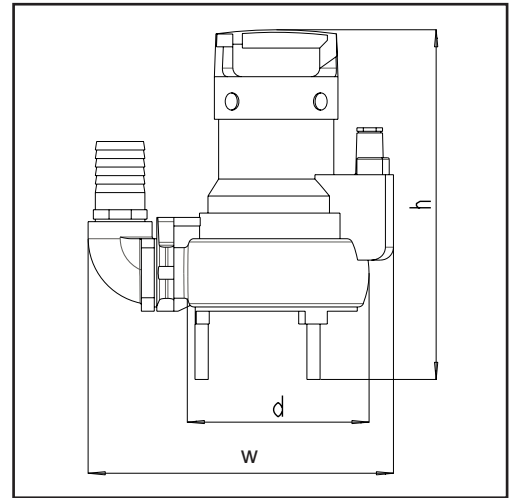

Pump type	P2 [kW]	Rated current [A]	Connect Voltage [V]	Motor Voltage [V]	Thermal Motor Monitoring	Electric cable n x [mm ²]	Electric connection	Impeller diam. [mm]	Free passage [mm]	h x w x d [mm]	Pump control
88-2 110	0,75	2,80	3 * 400	3 * 400	~	4 x 1	Cable	110	60	410 x 364 x 224	No
88-2A 110	0,75	2,80	3 * 400	3 * 400	~	4 x 1	Cable	110	60	412 x 374 x 223	Autom
88-2W 110	0,75	6,00	1 * 230	1 * 230	Clixon	3 x 1	Cable+plug	110	60	410 x 364 x 224	No
88-2WA 110	0,75	6,00	1 * 230	1 * 230	Clixon	3 x 1	Cable+plug	110	60	412 x 374 x 223	Autom
88-2WS 110	0,75	6,00	1 * 230	1 * 230	Clixon	3 x 1	Cable+plug	110	60	410 x 364 x 224	Floatswitch
811-2 120	1,10	3,00	3 * 400	3 * 400	~	4 x 1	Cable	120	58	410 x 364 x 224	No
811-2A 120	1,10	3,00	3 * 400	3 * 400	~	4 x 1	Cable	120	58	412 x 374 x 223	Autom
811-2W 120	1,10	8,20	1 * 230	1 * 230	Clixon	3 x 1	Cable+plug	120	58	410 x 364 x 224	No
811-2W 130	1,10	8,20	1 * 230	1 * 230	Clixon	3 x 1	Cable+plug	130	56	410 x 364 x 224	No
811-2WA 120	1,10	8,20	1 * 230	1 * 230	Clixon	3 x 1	Cable+plug	120	58	412 x 374 x 223	Autom
811-2WA 130	1,10	8,20	1 * 230	1 * 230	Clixon	3 x 1	Cable+plug	130	56	412 x 374 x 223	Autom
811-2WS 120	1,10	8,20	1 * 230	1 * 230	Clixon	3 x 1	Cable+plug	120	58	410 x 364 x 224	Floatswitch
811-2WS 130	1,10	8,20	1 * 230	1 * 230	Clixon	3 x 1	Cable+plug	130	56	410 x 364 x 224	Floatswitch
815-2 130	1,50	3,50	3 * 400	3 * 400	~	4 x 1	Cable	130	56	410 x 364 x 224	No
815-2A 130	1,50	3,50	3 * 400	3 * 400	~	4 x 1	Cable	130	56	412 x 374 x 223	Autom

DRV 8 2850 min⁻¹ 50Hz

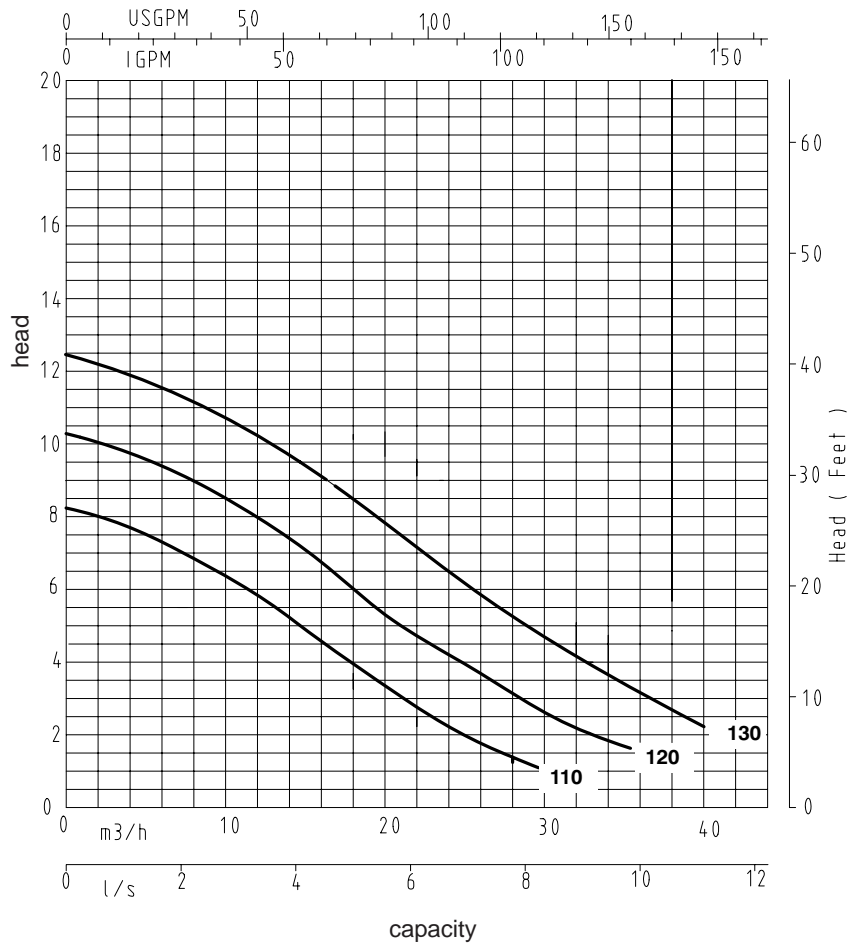

DRV 9

Connection [G]/[DN]	50
Flange [PN]	16
Pump Casing	JL 1040
Impeller	JL 1040
Shaft	1.4021
Shaft seal pump side	SiC/SiC
Shaft seal motor side	Ca/Ce
Elastomer components	NBR
Connect Voltage [V]	3 * 400
Motor Voltage [V]	3 * 400
IP	68
Insulation Class	F
Thermal Motor Monitoring	Bi-metal
Electric cable n x [mm ²]	7 x 1,5
Electric connection	Cable
Length electric cable [m]	10
Nom. speed [min ⁻¹]	2850
Free passage [mm]	40
h x w x d [mm]	470 x 322 x 250
Temp. Max pumped liquid [°C]	55
Pump control	No

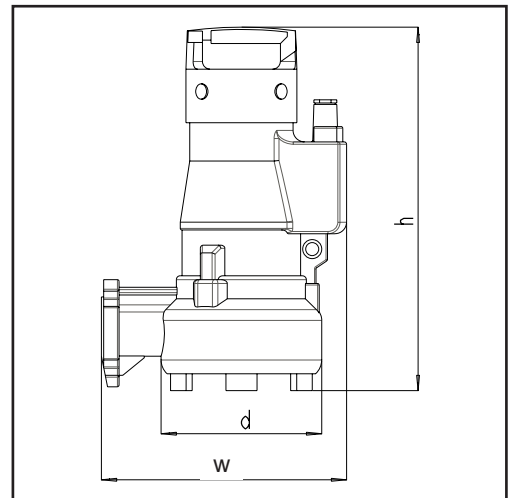

Pump type	P2 [kW]	Rated current [A]	Impeller diam. [mm]	Weight [kg]
913-2 90	1,30	3,56	90	41
913-2 107	1,30	3,56	107	41
919-2 120	1,90	4,50	120	42
923-2 130	2,30	5,10	130	42

Special versions

"E" Explosion proof according to Eex d IIB T4

"HT" High temperature version for temperatures up to max. 60 °C.



DRV 9 2850 min⁻¹ 50Hz

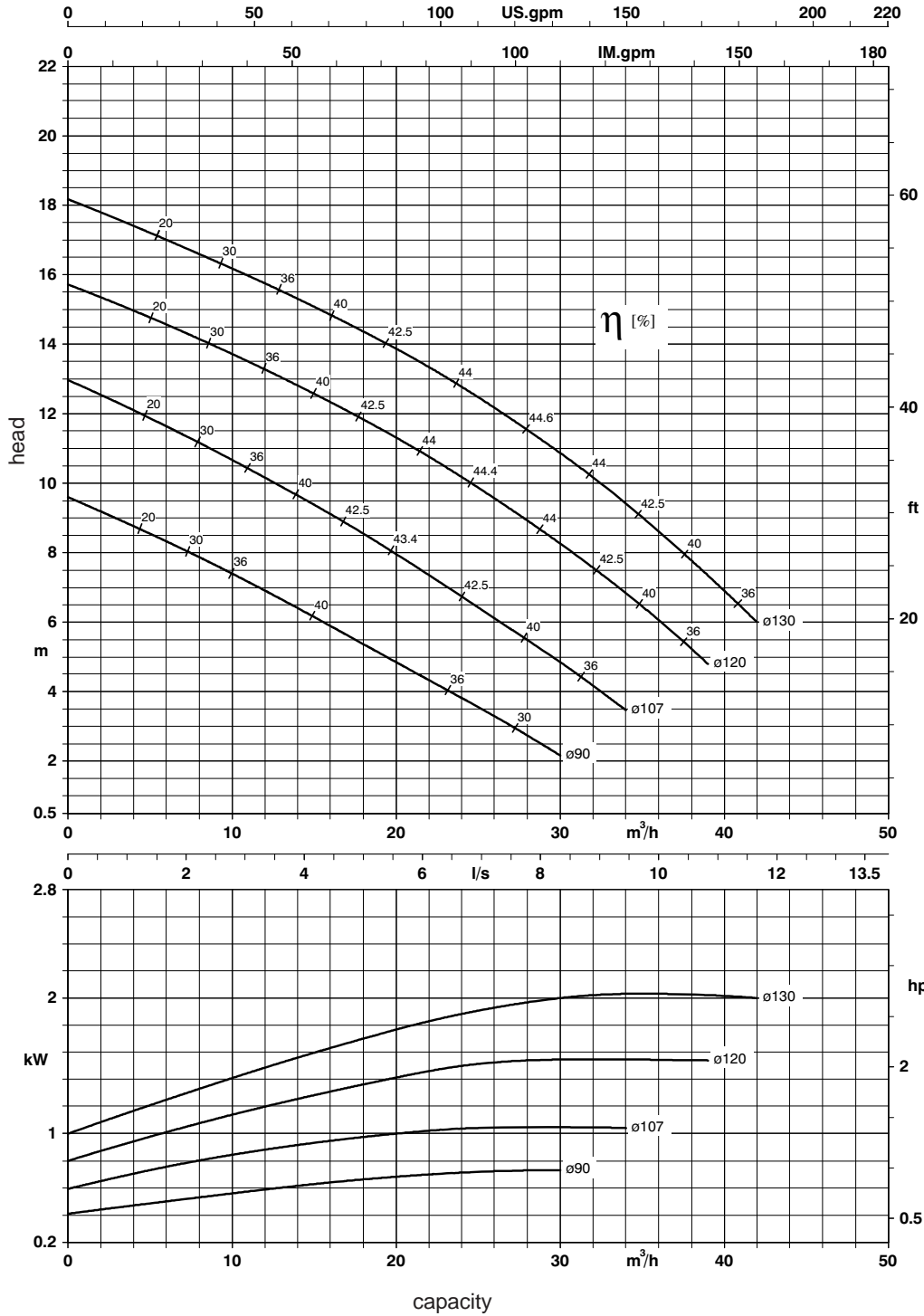

DRV 11

Connection [G]/[DN]	50
Flange [PN]	16
Pump casing	JL 1040
Impeller	JL 1040
Shaft	1.4021
Shaft seal pump side	SiC/SiC
Shaft seal motor side	Ca/Ce
Elastomer components	NBR
Connect Voltage [V]	3 * 400
Motor Voltage [V]	3 * 400
IP	68
Insulation Class	F
Thermal Motor Monitoring	Bi-metal
Electric cable n x [mm ²]	7 x 1,5
Electric connection	Cable
Length electric cable [m]	10
Nom. speed [min-1]	2850
Free passage [mm]	40
h x w x d [mm]	532 x 336 x 254
Temp. Max pumped liquid [°C]	55
Pump control	No

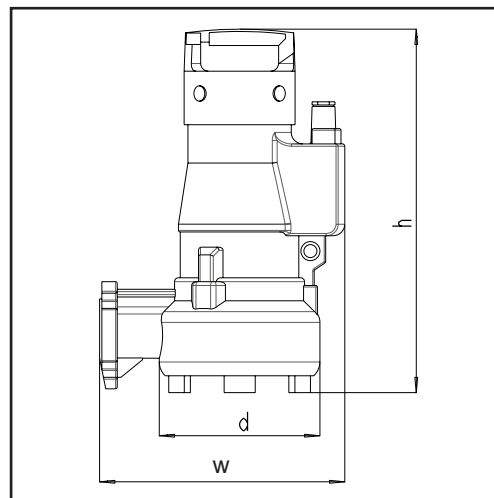

Pump type	P2 [kW]	Rated current [A]	Impeller diam. [mm]	Weight [kg]
1131-2 130	3,10	7,00	130	52
1131-2 140	3,10	7,00	140	52
1142-2 150	4,20	8,80	150	53

Special versions

"E" Explosion proof according to Eex d IIB T4

"HT" High temperature version for temperatures up to max. 60 °C.



DRV 11 2850 min⁻¹ 50Hz

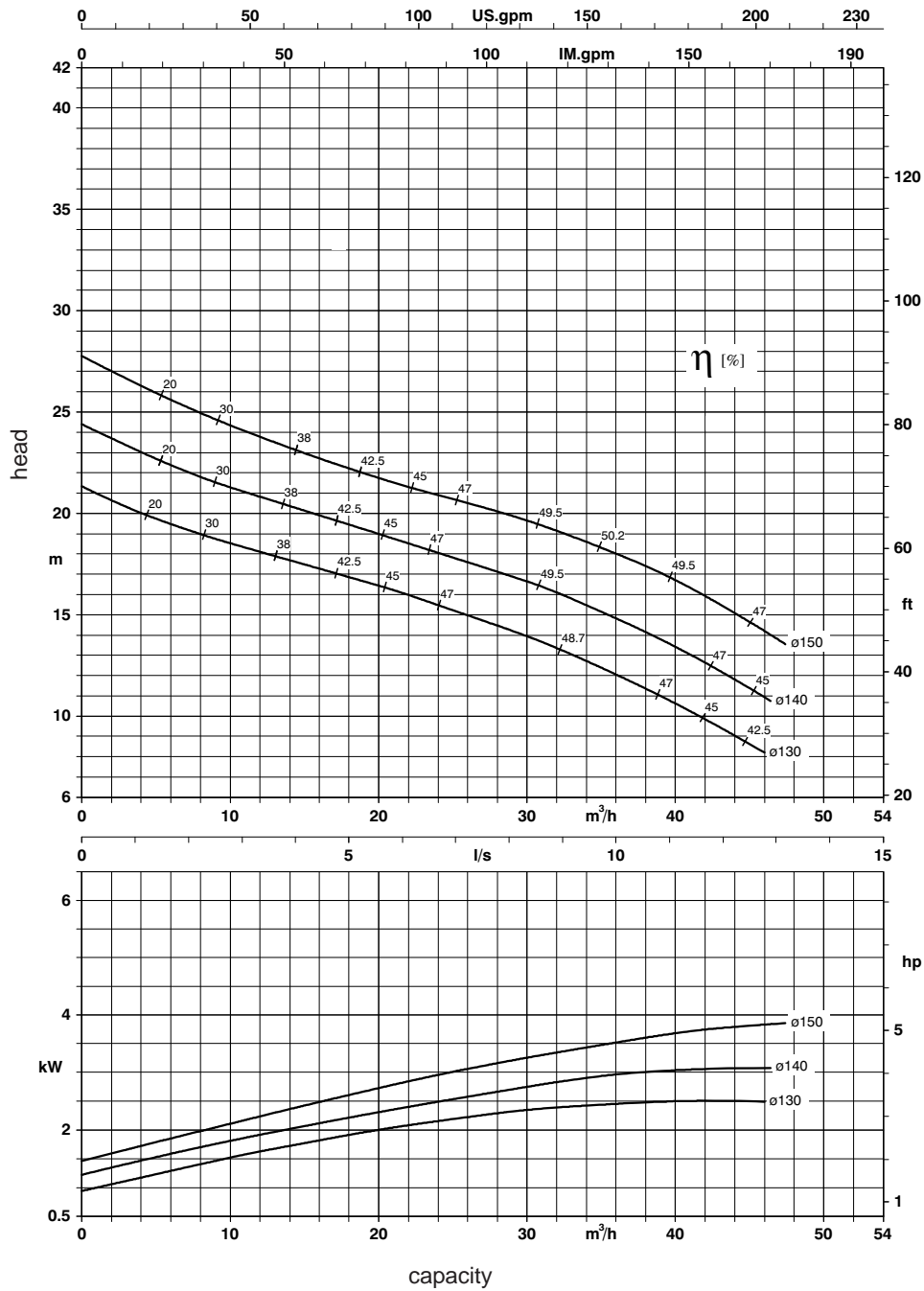

DRV 12

Connection [G]/[DN]	65
Flange [PN]	16
Pump casing	JL 1040
Impeller	JL 1040
Shaft	1.4021
Shaft seal pump side	SiC/SiC
Shaft seal motor side	Ca/Ce
Elastomer components	NBR
Connect Voltage [V]	3 * 400
Motor Voltage [V]	3 * 400
IP	68
Insulation Class	F
Thermal Motor Monitoring	Bi-metal
Electric cable n x [mm ²]	7 x 1,5
Electric connection	Cable
Length electric cable [m]	10
Nom. speed [min ⁻¹]	1450
Free passage [mm]	65
h x w x d [mm]	518 x 353 x 265
Temp. Max pumped liquid [°C]	55
Pump control	No

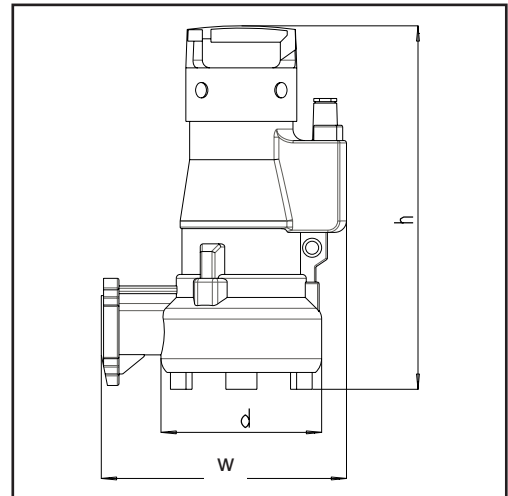

Pump type	P2 [kW]	Rated current [A]	Impeller diam. [mm]	Weight [kg]
128-4 112	0,80	2,75	112	49
128-4 125	0,80	2,75	125	49
128-4 135	0,80	2,75	135	49
128-4 145	0,80	2,75	145	49
128-4 155	0,80	2,75	155	49
1213-4 165	1,30	3,54	165	50
1213-4 175	1,30	3,54	175	50
1218-4 185	1,80	4,25	185	51
1218-4 195	1,80	4,25	195	51

Special versions

"E" Explosion proof according to Eex d IIB T4

"HT" High temperature version for temperatures up to max. 60 °C.



DRV 12 1450 min⁻¹ 50Hz

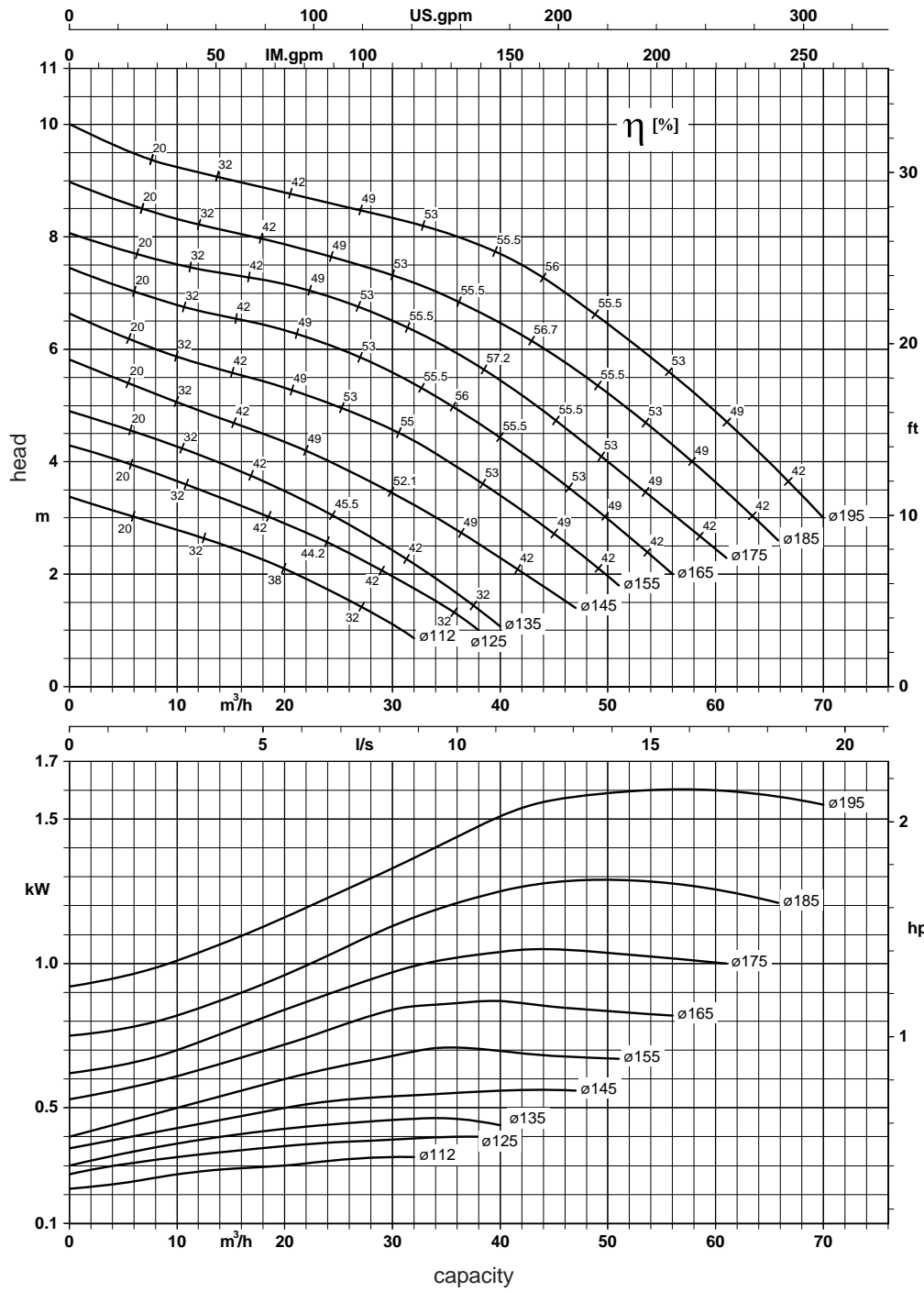

DRV 13

Connection [G]/[DN]	65
Flange [PN]	16
Pump casing	JL 1040
Impeller	JL 1040
Shaft	1.4021
Shaft seal pump side	SiC/SiC
Shaft seal motor side	Ca/Ce
Elastomer components	NBR
Connect Voltage [V]	3 * 400
Motor Voltage [V]	3 * 400
IP	68
Insulation Class	F
Thermal Motor Monitoring	Bi-metal
Electric cable n x [mm ²]	7 x 1,5
Electric connection	Cable
Length electric cable [m]	10
Nom. speed [min ⁻¹]	2850
Free passage [mm]	65
h x w x d [mm]	578 x 367 x 251
Temp. Max pumped liquid [°C]	55
Pump control	No

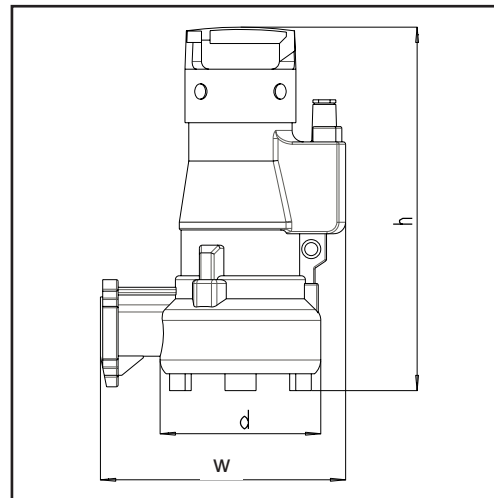

Pump type	P2 [kW]	Rated current [A]	Impeller diam. [mm]	Weight [kg]
1331-2 120	3,10	7,00	120	58
1331-2 128	3,10	7,00	128	58
1331-2 136	3,10	7,00	136	59
1342-2 146	4,20	8,80	146	59
1342-2 152	4,20	8,80	152	60

Special versions

"E" Explosion proof according to Eex d IIB T4

"HT" High temperature version for temperatures up to max. 60 °C.



DRV 13 2850 min⁻¹ 50Hz

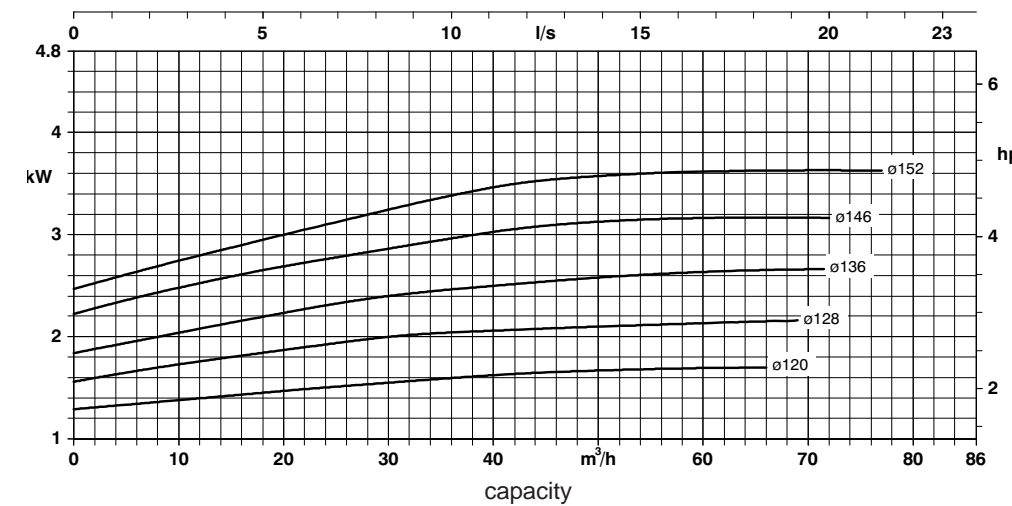
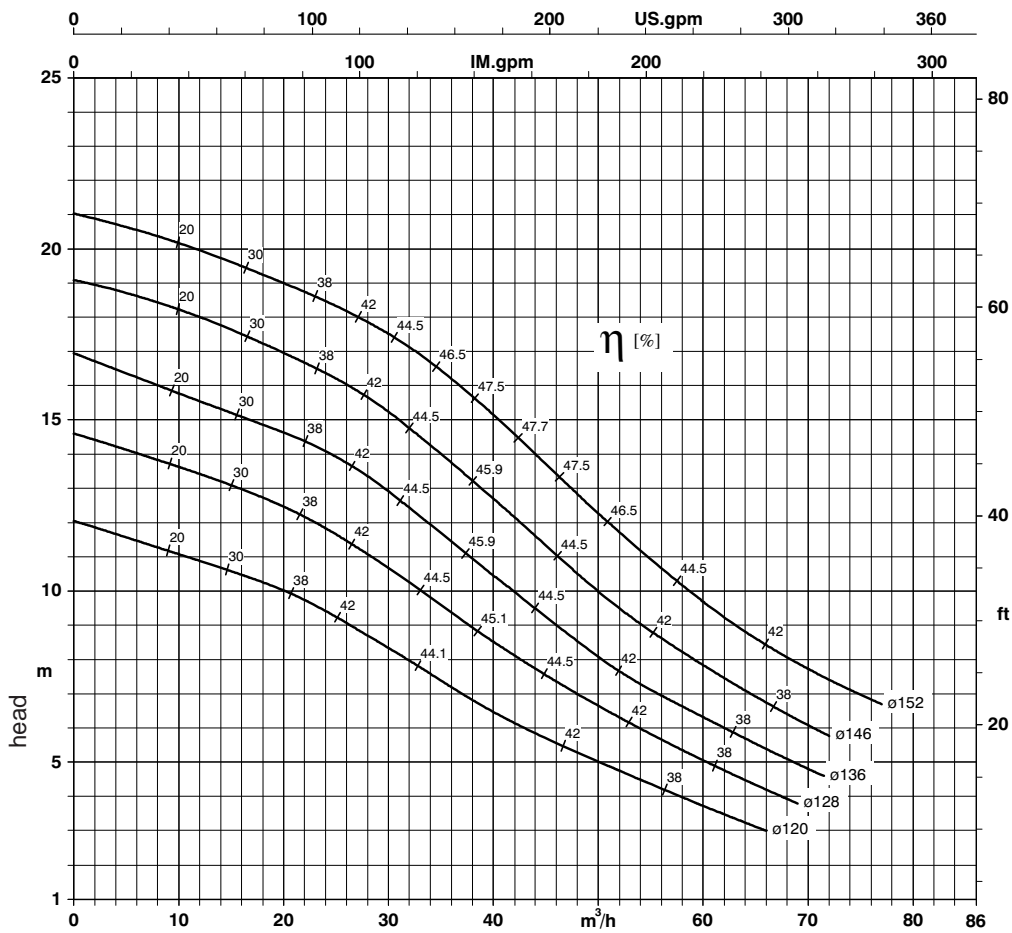

DRV 24

Connection [G]/[DN]	80
Flange [PN]	16
Pump casing	JL 1040
Impeller	JL 1040
Shaft	1.4021
Shaft seal pump side	SiC/SiC
Shaft seal motor side	Ca/Ce
Elastomer components	NBR
Connect Voltage [V]	3 * 400
Motor Voltage [V]	3 * 400
IP	68
Insulation Class	F
Thermal Motor Monitoring	Bi-metal
Electric cable n x [mm ²]	7 x 1,5
Electric connection	Cable
Length electric cable [m]	10
Nom. speed [min ⁻¹]	1450
Free passage [mm]	76
h x w x d [mm]	582 x 392 x 322
Temp. Max pumped liquid [°C]	55
Pump control	No

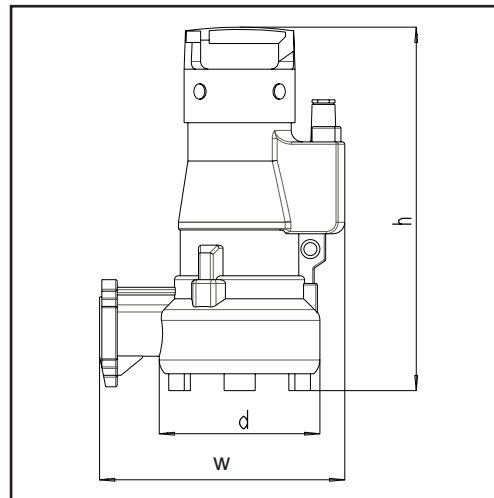

Pump type	P2 [kW]	Rated current [A]	Impeller diam. [mm]	Weight [kg]
2419-4 120	1,90	5,87	120	63
2419-4 135	1,90	5,87	135	63
2419-4 150	1,90	5,87	150	63
2426-4 165	2,60	6,50	165	64
2437-4 180	3,70	8,40	180	65
2437-4 195	3,70	8,40	195	65

Special versions

"E" Explosion proof according to Eex d IIB T4

"HT" High temperature version for temperatures up to max. 60 °C.



DRV 24 1450 min⁻¹ 50Hz

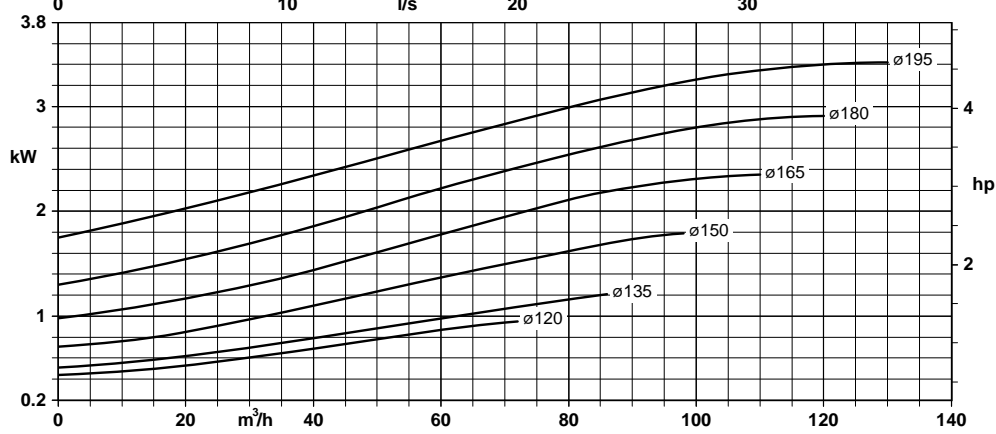
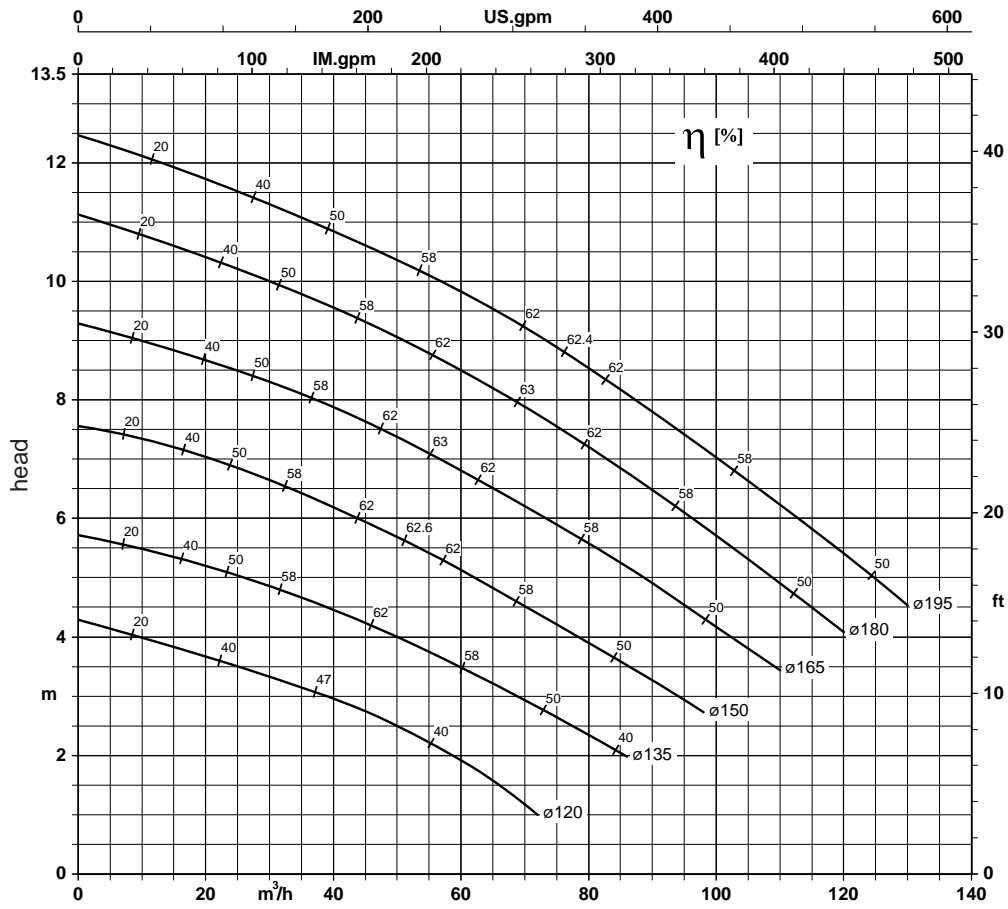

capacity

DRV 27

Connection [G]/[DN]	100
Flange [PN]	16
Pump casing	JL 1040
Impeller	JL 1040
Shaft	1.4021
Shaft seal pump side	SiC/SiC
Shaft seal motor side	Ca/Ce
Elastomer components	NBR
Motor Voltage [V]	3 * 400
IP	68
Insulation Class	F
Thermal Motor Monitoring	Bi-metal
Electric cable n x [mm ²]	7 x 1,5
Electric connection	Cable
Length electric cable [m]	10
Nom. speed [min ⁻¹]	1450
Free passage [mm]	100
h x w x d [mm]	603 x 383 x 318
Temp. Max pumped liquid [°C]	55
Pump control	No

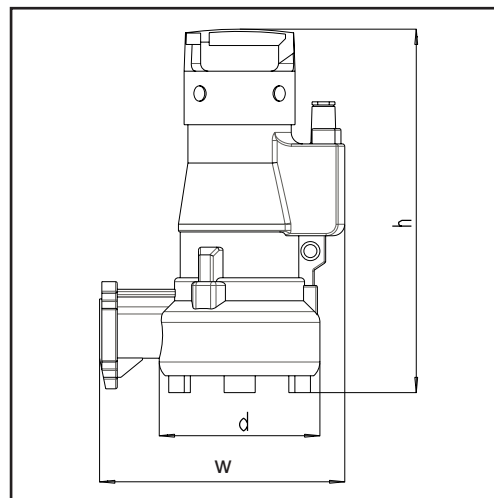

Pump type	P2 [kW]	Rated current [A]	Connect Voltage [V]	Impeller diam. [mm]	Weight [kg]
2719-4 120	1,90	5,87	3 * 400	120	64
2719-4 135	1,90	5,87	3 * 400	135	64
2726-4 150	2,60	6,50	3 * 400	150	64
2737-4 165	3,70	8,40	3 * 400	165	65
2737-4 180	3,70	8,40	3 * 400	180	66
2737-4 195	3,70	8,40	3 * 400	195	67

Special versions

"E" Explosion proof according to Eex d IIB T4

"HT" High temperature version for temperatures up to max. 60 °C.



DRV 27 1450 min⁻¹ 50Hz

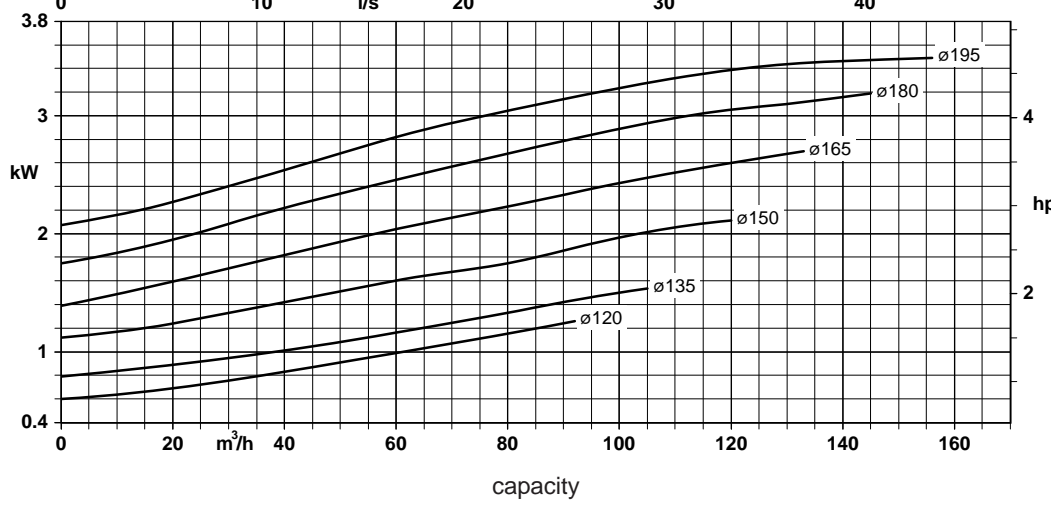
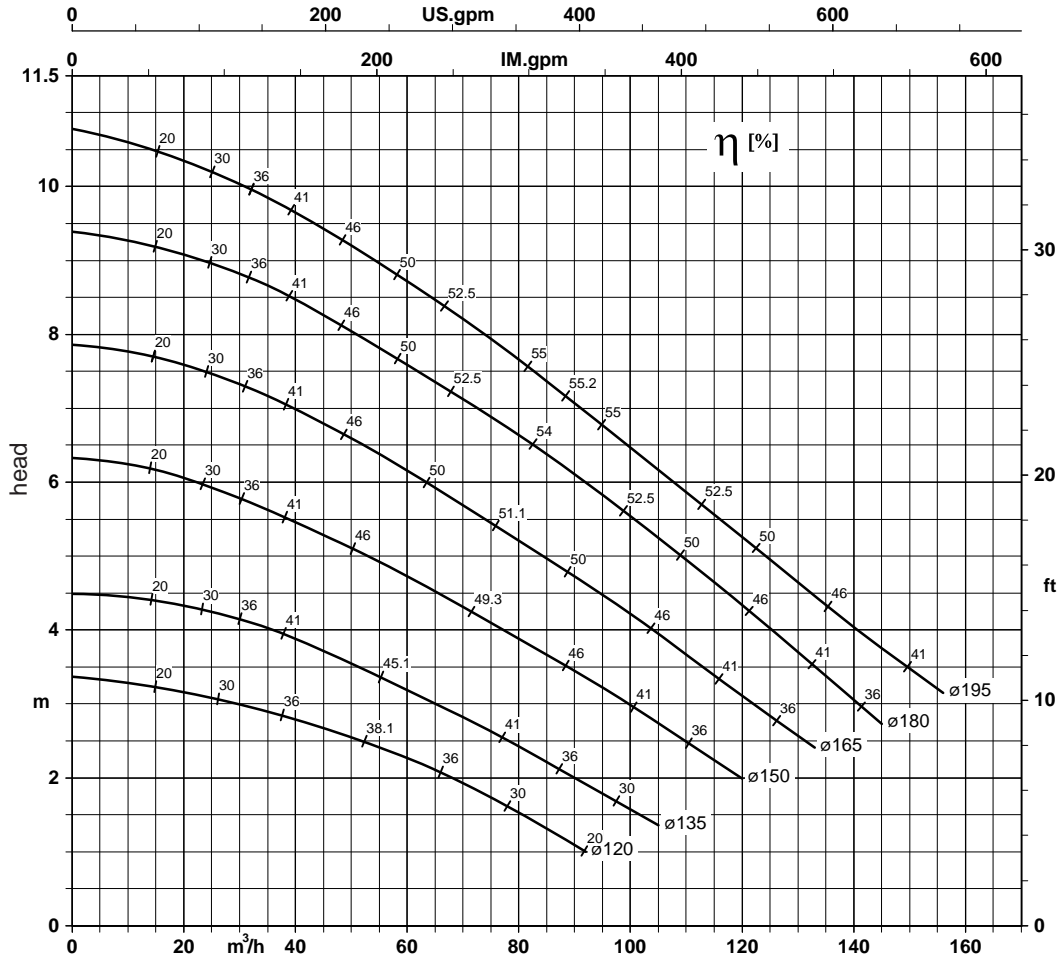

DRSK 21

Connection [G]/[DN]	80
Flange [PN]	16
Pump casing	JL 1040
Impeller	JL 1040
Shaft	1.4021
Shaft seal pump side	SiC/SiC
Shaft seal motor side	Ca/Ce
Elastomer components	NBR
P2 [kW]	1,90
Rated current [A]	5,87
Motor Voltage [V]	3 * 400
IP	68
Insulation Class	F
Thermal Motor Monitoring	Bi-metal
Electric cable n x [mm ²]	7 x 1,5
Electric connection	Cable
Length electric cable [m]	10
Nom. speed [min ⁻¹]	1450
Free passage [mm]	65
h x w x d [mm]	602 x 392 x 322
Temp. Max pumped liquid [°C]	55
Pump control	No

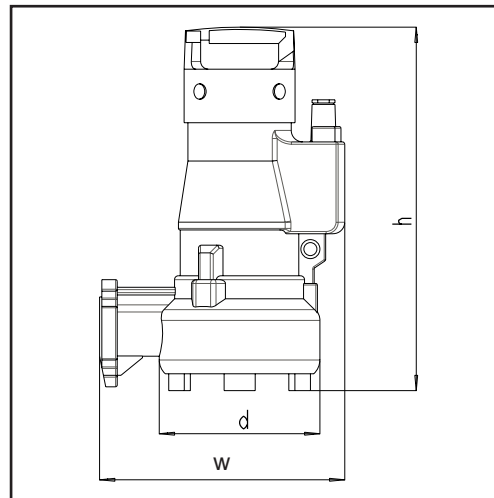

Pump type	Connect Voltage [V]	Impeller diam. [mm]	Weight [kg]
2119-4 154	3 * 400	154	74
2119-4 168	3 * 400	168	74
2119-4 180	3 * 400	180	74
2119-4 190	3 * 400	190	75

Special versions

"E" Explosion proof according to Eex d IIB T4

"HT" High temperature version for temperatures up to max. 60 °C.



DRSK 21 1450 min⁻¹ 50Hz

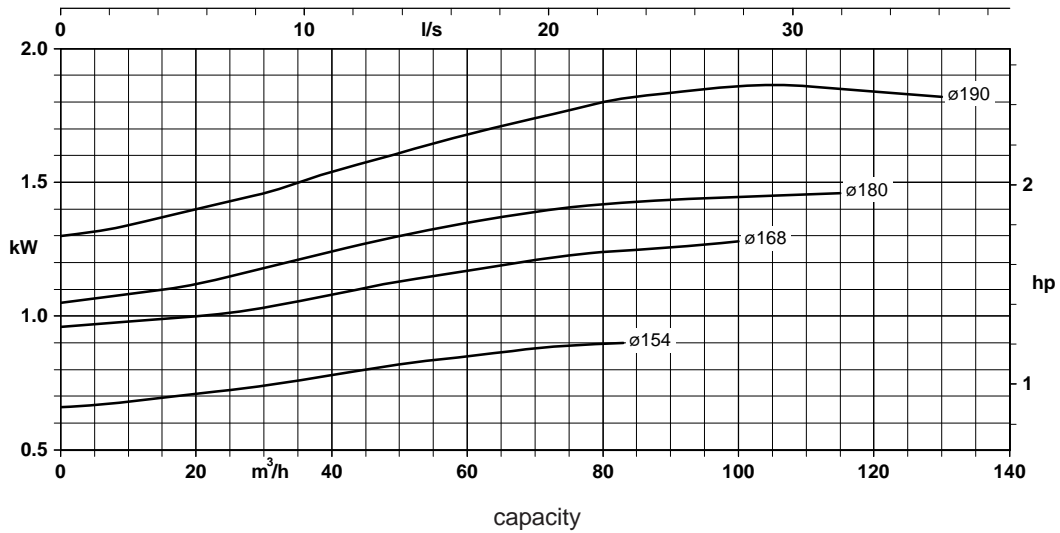
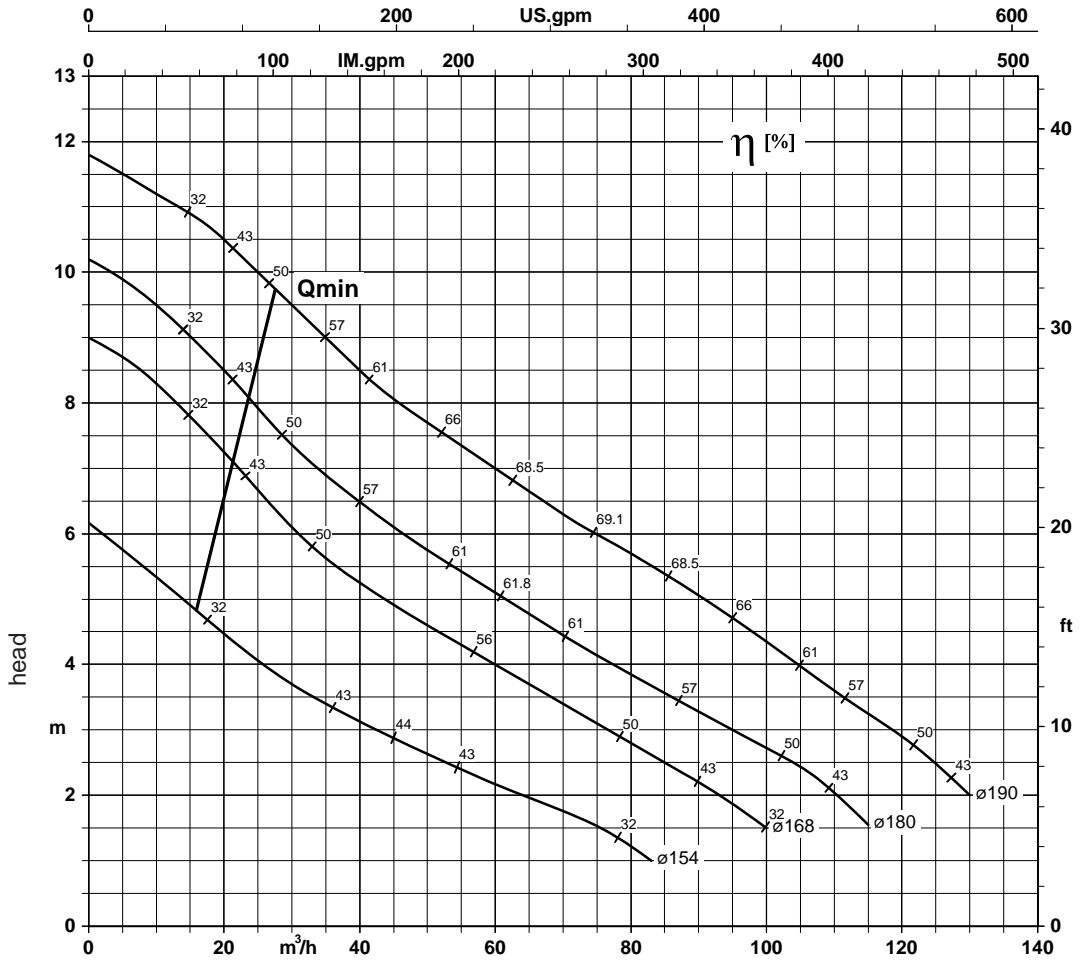

DRSK 31

Connection [G]/[DN]	100
Flange [PN]	16
Pump casing	JL 1040
Impeller	JL 1040
Shaft	1.4021
Shaft seal pump side	SiC/SiC
Shaft seal motor side	Ca/Ce
Elastomer components	NBR
Connect Voltage [V]	3 * 400
Motor Voltage [V]	3 * 400
IP	68
Insulation Class	F
Thermal Motor Monitoring	Bi-metal
Electric cable n x [mm ²]	7 x 1,5
Electric connection	Cable
Length electric cable [m]	10
Nom. speed [min ⁻¹]	1450
Free passage [mm]	76
h x w x d [mm]	628 x 383 x 318
Temp. Max pumped liquid [°C]	55
Pump control	No

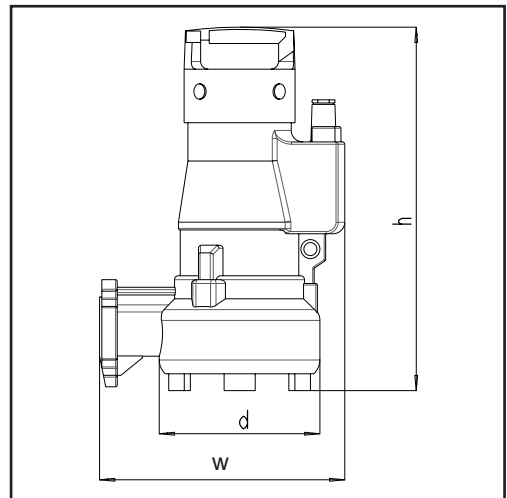

Pump type	P2 [kW]	Rated current [A]	Impeller diam. [mm]	Weight [kg]
3126-4 195	2,60	6,50	195	79
3137-4 209	3,70	8,40	209	79
3137-4 220	3,70	8,40	220	80

Special versions

"E" Explosion proof according to Eex d IIB T4

"HT" High temperature version for temperatures up to max. 60 °C.



DRSK 31 1450 min⁻¹ 50Hz

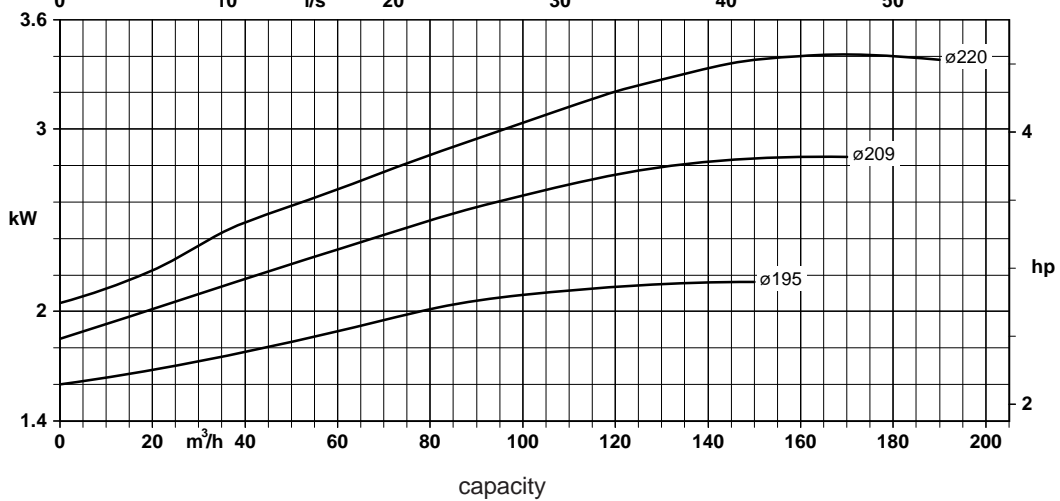
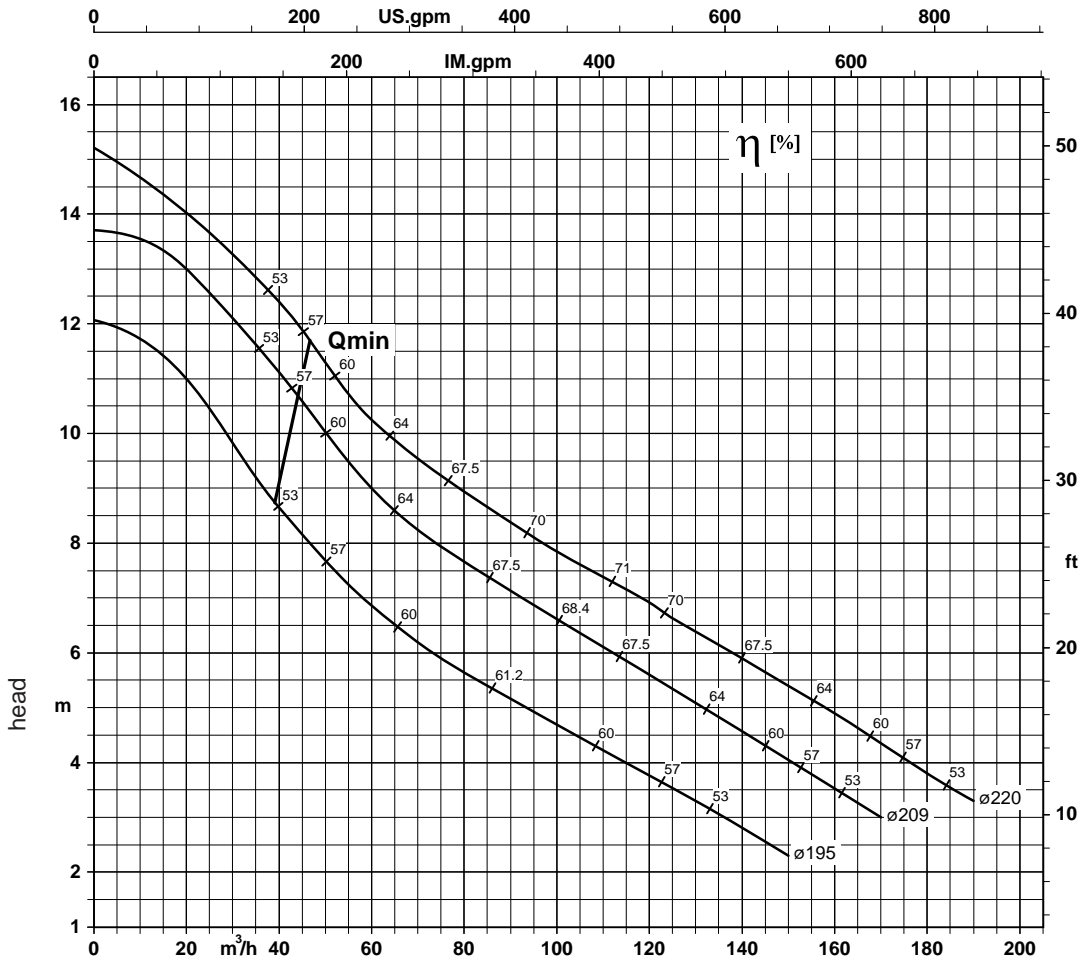

DRS 3

Connection [G]/[DN]	50
Flange [PN]	6
Pump casing	JL 1030
Impeller	JL 1030
Shaft	1.4021
Shaft seal pump side	SiC/SiC
Shaft seal motor side	seal ring
Elastomer components	NBR
IP	68
Insulation Class	F
Electric cable n x [mm ²]	4 x 1
Length electric cable [m]	10
Nom. speed [min ⁻¹]	2850
Impeller diam. [mm]	145
Free passage [mm]	7
Temp. Max pumped liquid [°C]	40

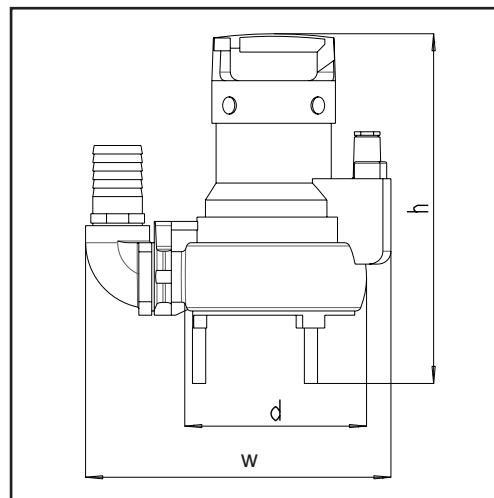

Pump type	P2 [kW]	Rated current [A]	Connect Voltage [V]	Motor Voltage [V]	Thermal Motor Monitoring	Electric connection	h x w x d [mm]	Pump control	Weight [kg]
311-2W 145	1,10	8,20	1 * 230	1 * 230	Clixon	Cable+plug	396 x 318 x 198	No	26
311-2WA 145	1,10	8,20	1 * 230	1 * 230	Clixon	Cable+plug	396 x 328 x 198	Autom	26
311-2WS 145	1,10	8,20	1 * 230	1 * 230	Clixon	Cable+plug	396 x 318 x 198	Floatswitch	26
315-2 145	1,50	3,50	3 * 400	3 * 400	~	Cable	396 x 318 x 198	No	24
315-2A 145	1,50	3,50	3 * 400	3 * 400	~	Cable	396 x 328 x 198	Autom	24



DRS 3 2850 min⁻¹ 50Hz 1*230V

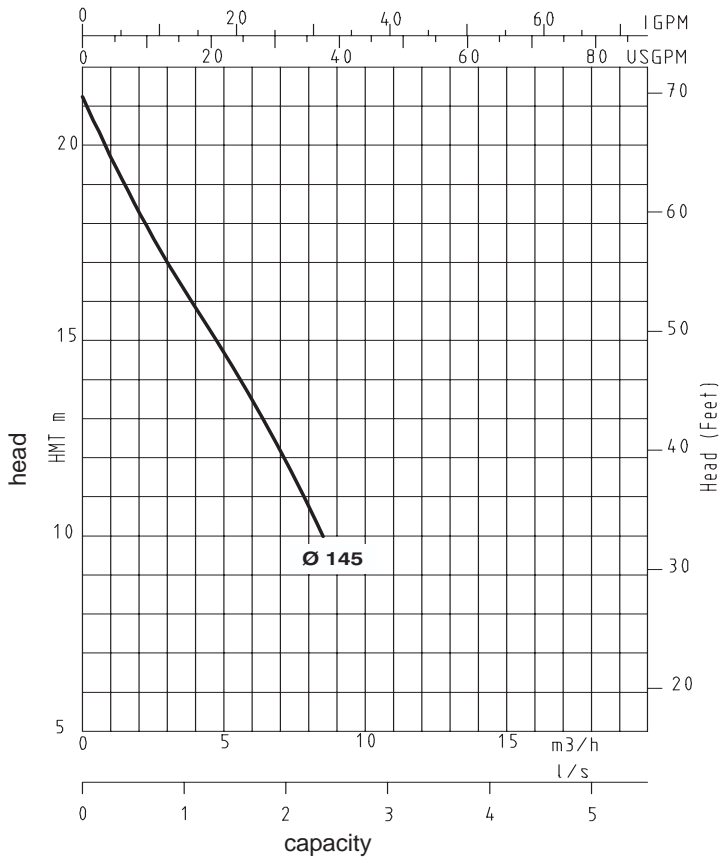

DRS 3 2850 min⁻¹ 50Hz 3*400V

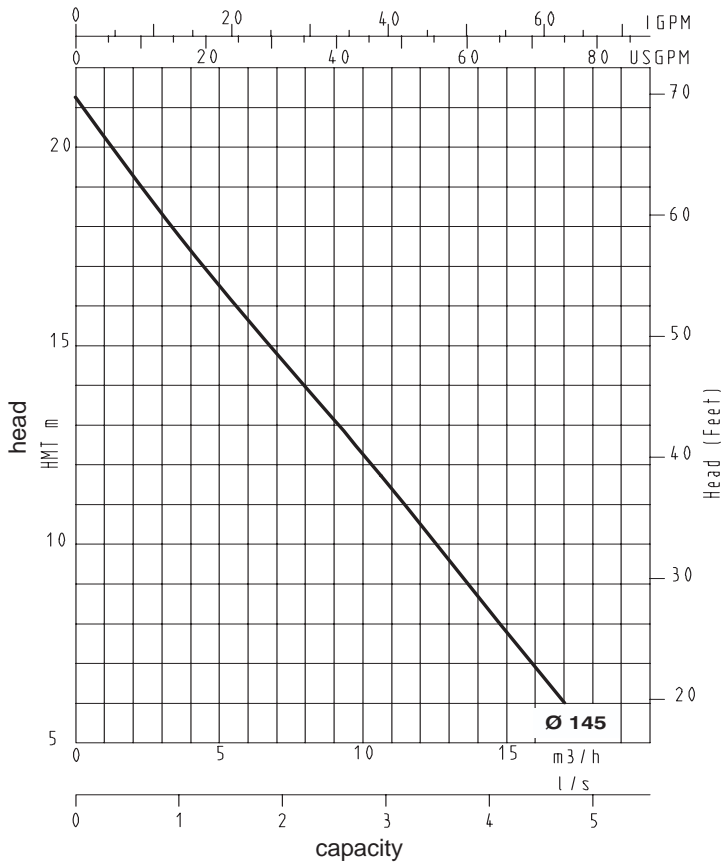

DRS 4

Connection [G]/[DN]	50
Flange [PN]	16
Pump casing	JL 1040
Impeller	JL 1040
Shaft	1.4021
Shaft seal pump side	SiC/SiC
Shaft seal motor side	Ca/Ce
Elastomer components	NBR
Connect Voltage [V]	3 * 400
Motor Voltage [V]	3 * 400
IP	68
Insulation Class	F
Thermal Motor Monitoring	Bi-metal
Electric cable n x [mm ²]	7 x 1,5
Electric connection	Cable
Length electric cable [m]	10
Nom. speed [min ⁻¹]	2850
Free passage [mm]	6
h x w x d [mm]	470 x 322 x 250
Temp. Max pumped liquid [°C]	55
Pump control	No
Weight [kg]	39

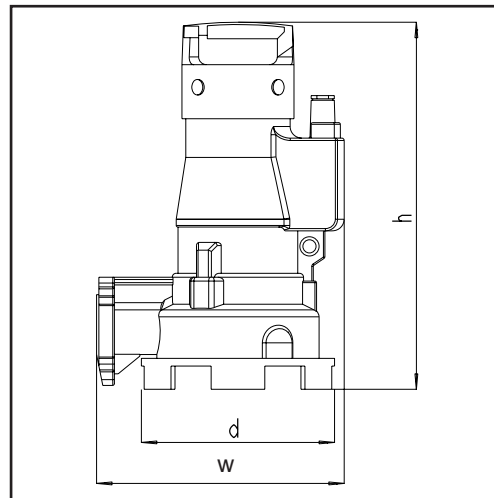

Pump type	P2 [kW]	Rated current [A]	Impeller diam. [mm]
413-2 120	1,30	3,56	120
413-2 140	1,30	3,56	140
419-2 160	1,90	4,50	160

Special versions

'E' Explosion proof according to Eex d IIB T4

'HT' High temperature version for temperatures up to max. 60 °C



DRS 4 2850 min⁻¹ 50Hz

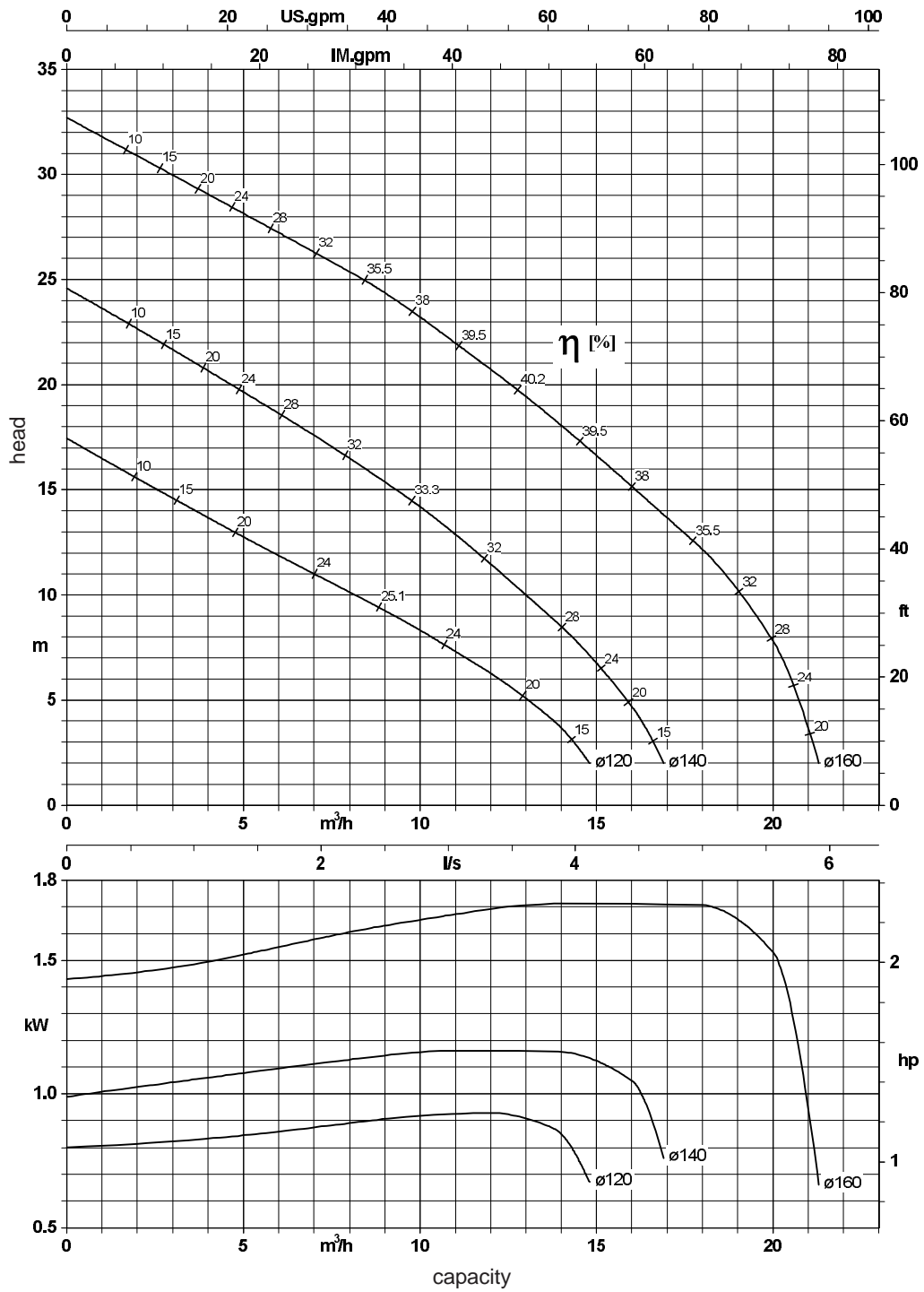

DRS 6

Connection [G]/[DN]	50
Flange [PN]	16
Pump casing	JL 1040
Impeller	JL 1040
Shaft	1.4021
Shaft seal pump side	SiC/SiC
Shaft seal motor side	Ca/Ce
Elastomer components	NBR
Connect Voltage [V]	3 * 400
Motor Voltage [V]	3 * 400
IP	68
Insulation Class	F
Thermal Motor Monitoring	Bi-metal
Electric cable n x [mm ²]	7 x 1,5
Electric connection	Cable
Length electric cable [m]	10
Nom. speed [min ⁻¹]	2850
Free passage [mm]	6
h x w x d [mm]	532 x 336 x 254
Temp. Max pumped liquid [°C]	55
Pump control	No
Weight [kg]	54

Pump type	P2 [kW]	Rated current [A]	Impeller diam. [mm]
631-2 175	3,10	7,00	175
642-2 190	4,20	8,80	190

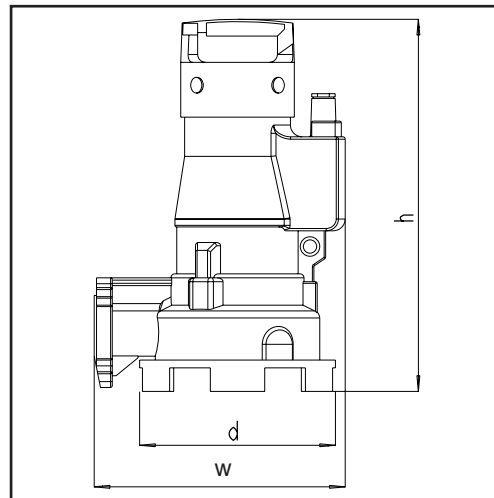

Special versions

'E' Explosion proof according to Eex d IIB T4

'HT' High temperature version for temperatures up to max. 60 °C



DRS 6 2850 min⁻¹ 50Hz

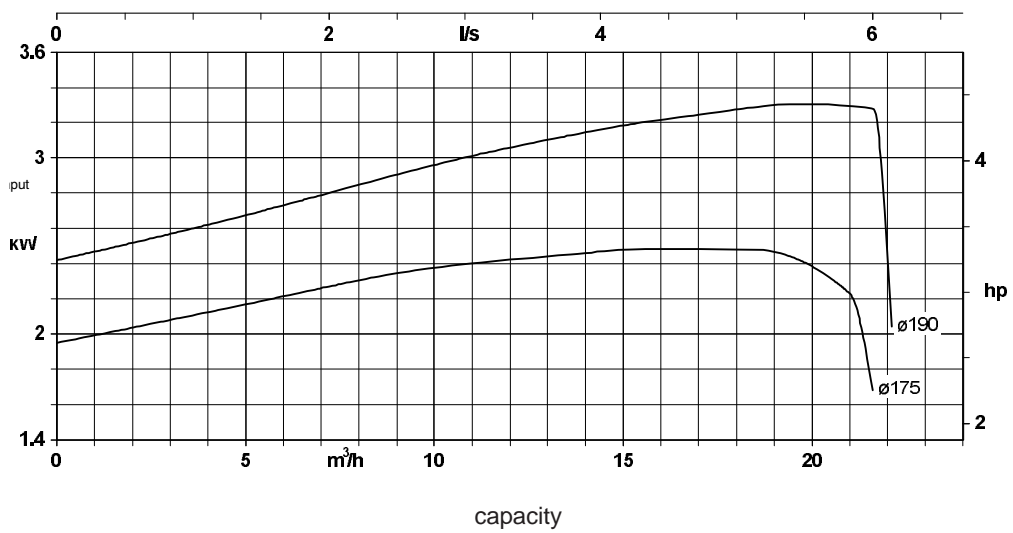
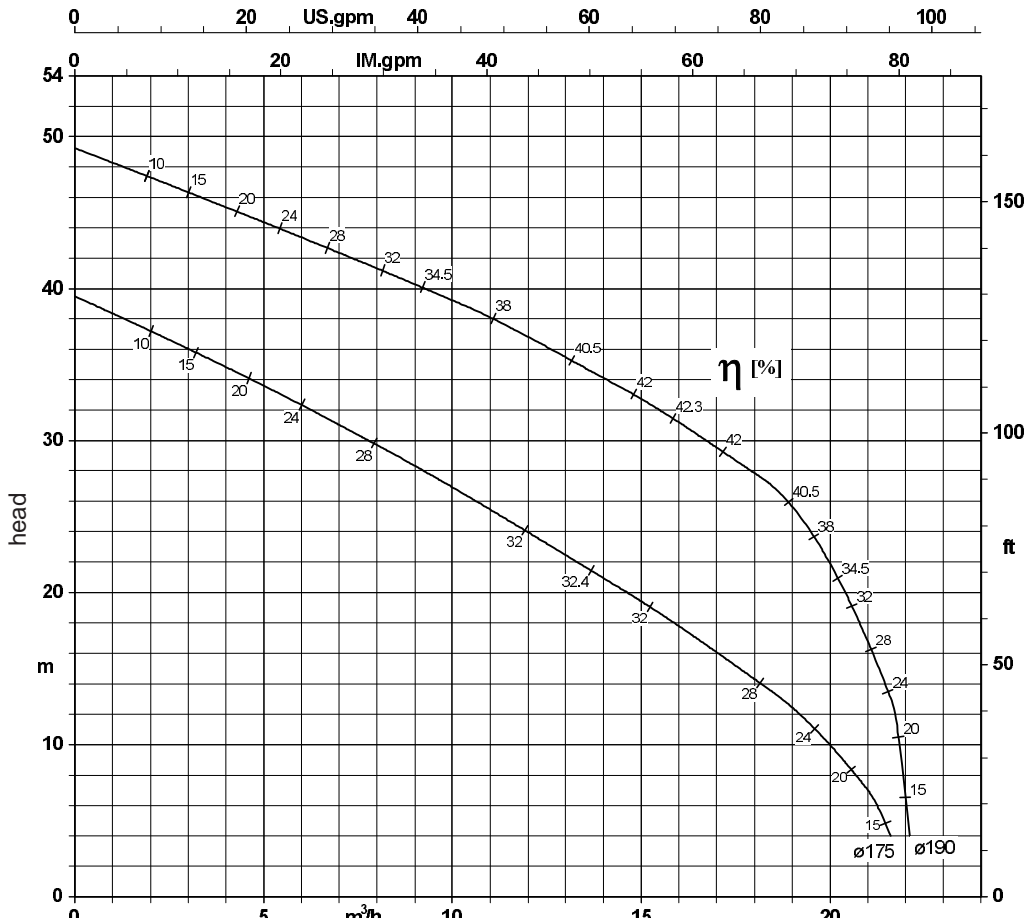

DRK 23

Connection [G]/[DN]	80
Pump casing	JL 1040
Impeller	JL 1040
Shaft	1.4021
Shaft seal pump side	SiC/SiC
Shaft seal motor side	Ca/SiC
Elastomer components	NBR
P2 [kW]	8,50
Rated current [A]	16,70
Connect Voltage [V]	3 * 400
Motor Voltage [V]	400/692
IP	68
Insulation Class	F
Thermal Motor Monitoring	Bi-metal
Electric cable n x [mm ²]	12*1,5
Electric connection	Cable
Length electric cable [m]	10
Nom. speed [min-1]	2905
Free passage [mm]	42
h x w x d [mm]	610 x 470 x 355
Temp. Max pumped liquid [°C]	40
Pump control	No
Weight [kg]	151

Pump type	Impeller diam. [mm]
2385-2 182	182
2385-2 196	196

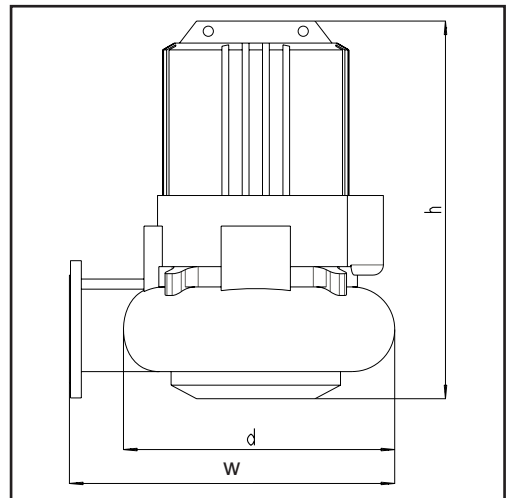

DRK 23 50Hz

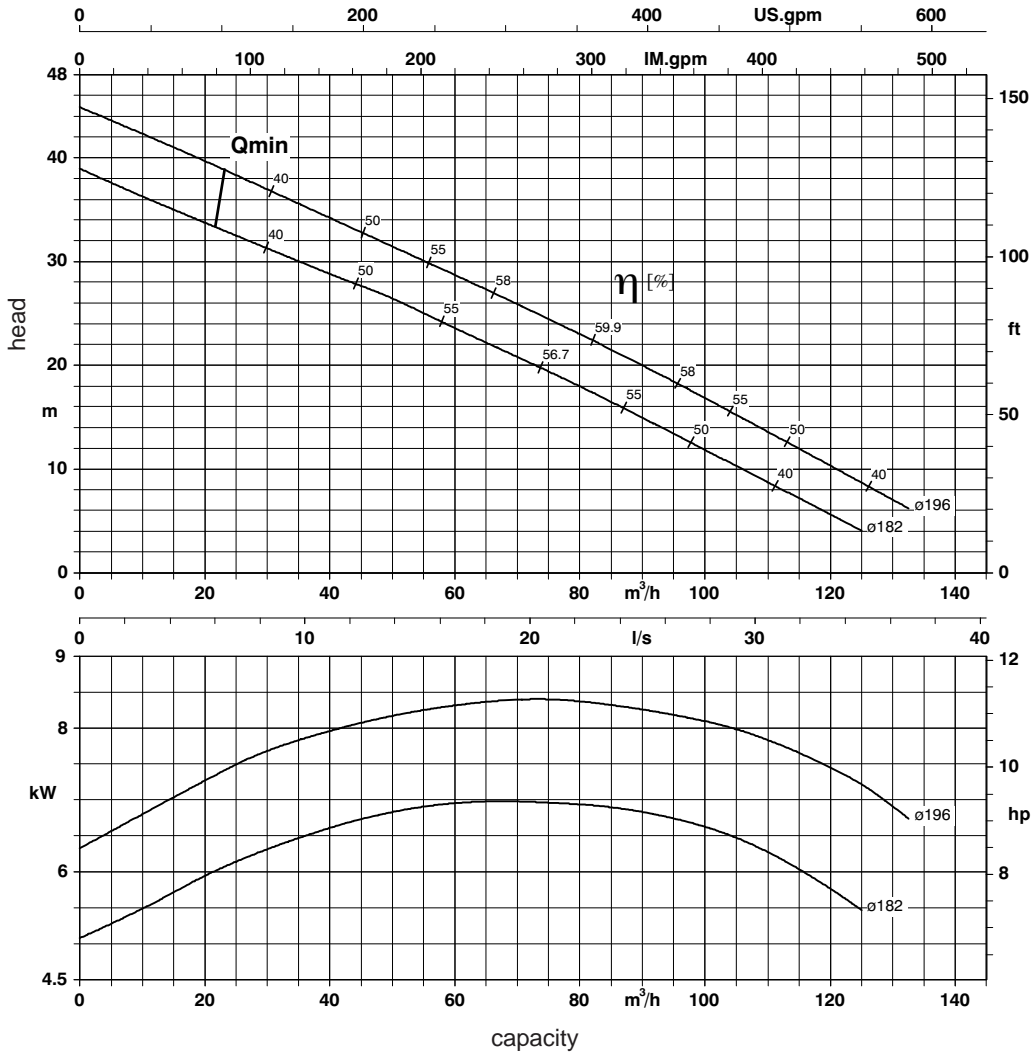

DRK 41

Connection [G]/[DN]	100
Flange [PN]	
Pump casing	JL 1040
Impeller	JL 1040
Shaft	1.4021
Shaft seal pump side	SiC/SiC
Shaft seal motor side	Ca/SiC
Elastomer components	NBR
Connect Voltage [V]	3 * 400
Motor Voltage [V]	400/692
IP	68
Insulation Class	F
Thermal Motor Monitoring	Bi-metal
Electric cable n x [mm ²]	12*1,5
Electric connection	Cable
Length electric cable [m]	10
Free passage [mm]	90
h x w x d [mm]	600 x 475 x 388
Temp. Max pumped liquid [°C]	40
Pump control	No

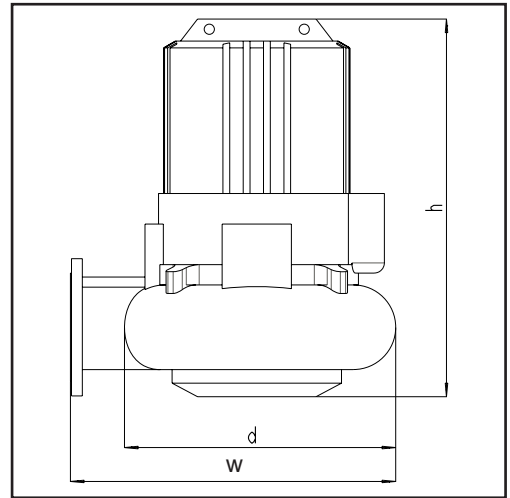

Pump type	P2 [kW]	Rated current [A]	Nom. speed [min-1]	Impeller diam. [mm]	Weight [kg]
4155-4 202	5,50	12,10	1430	202	141
4155-4 220	5,50	12,10	1430	220	141
4175-4 245	7,50	15,80	1440	245	155



DRK 41 50Hz

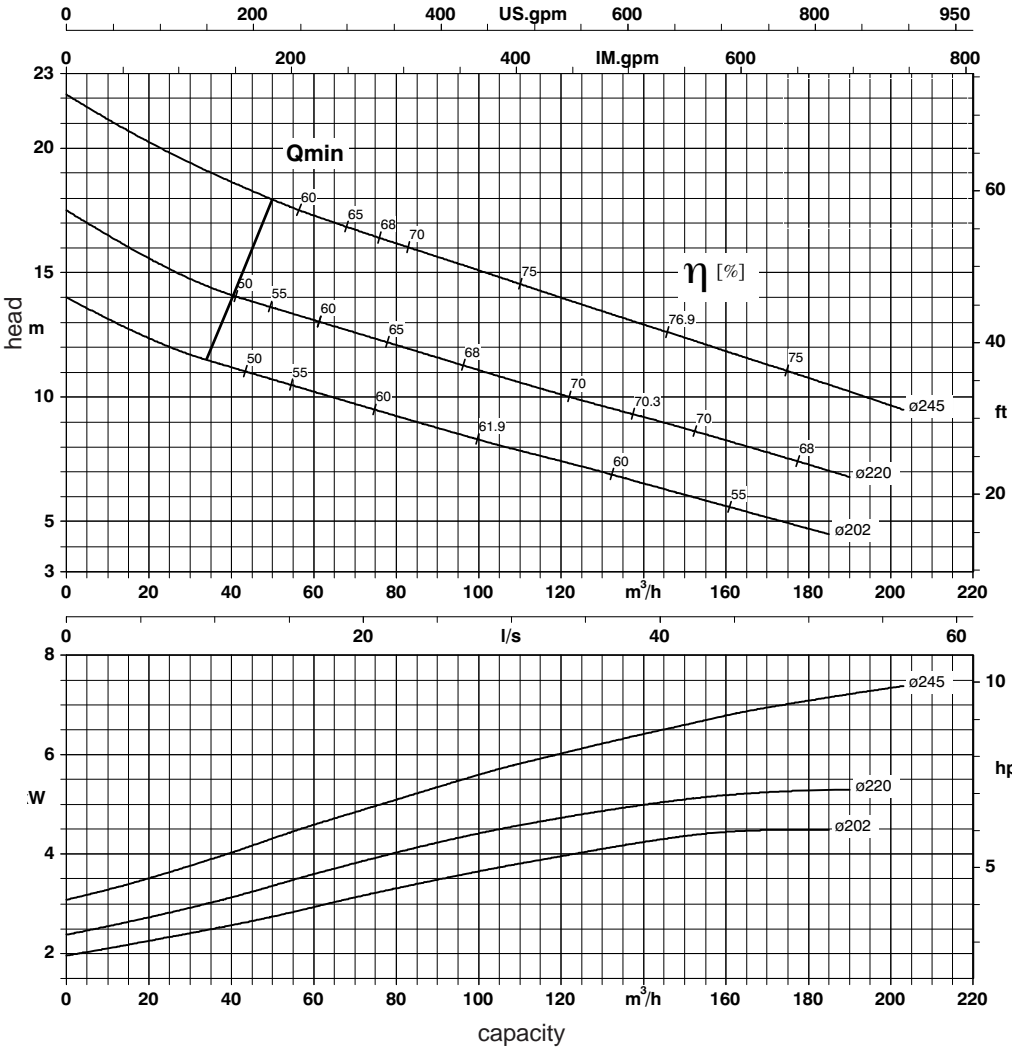

DRK 87

Connection [G]/[DN]	150
Pump Casing	JL 1040
Impeller	JL 1040
Shaft	1.4021
Shaft seal pump side	SiC/SiC
Shaft seal motor side	Ca/SiC
Elastomer components	NBR
Connect Voltage [V]	3 * 400
Motor Voltage [V]	400/692
IP	68
Isulation Class	F
Thermal Motor Monitoring	Bi-metal
Electric connection	Cable
Length electric cable [m]	10
Free passage [mm]	110
Temp. Max pumped liquid [°C]	40
Pump control	No

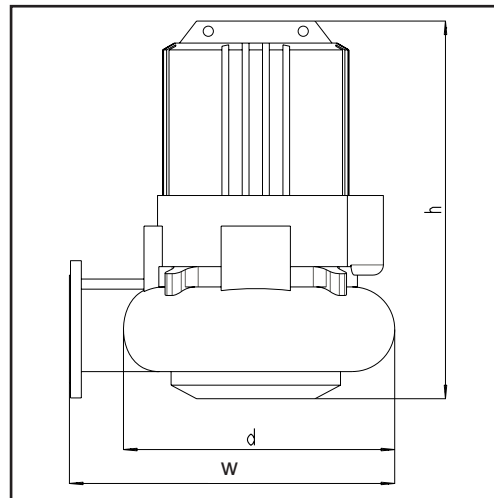

Pump type	P2 [kW]	Rated current [A]	Electric cable n x [mm ²]	Nom. speed [min ⁻¹]	Impeller diam. [mm]	h x w x d [mm]	Weight [kg]
87118-4 254	11,80	23,50	12*1,5	1465	254	740 x 640 x 535	146
87160-4 275	16,00	33,00	7*4+5*1,5	1465	275	740 x 640 x 535	256
87210-4 295	21,00	40,50	7*4+5*1,5	1435	295	880 x 640 x 535	325
87270-4 305	27,00	55,00	7*6+5*1,5	1455	305	850 x 640 x 535	343



DRK 87 50Hz

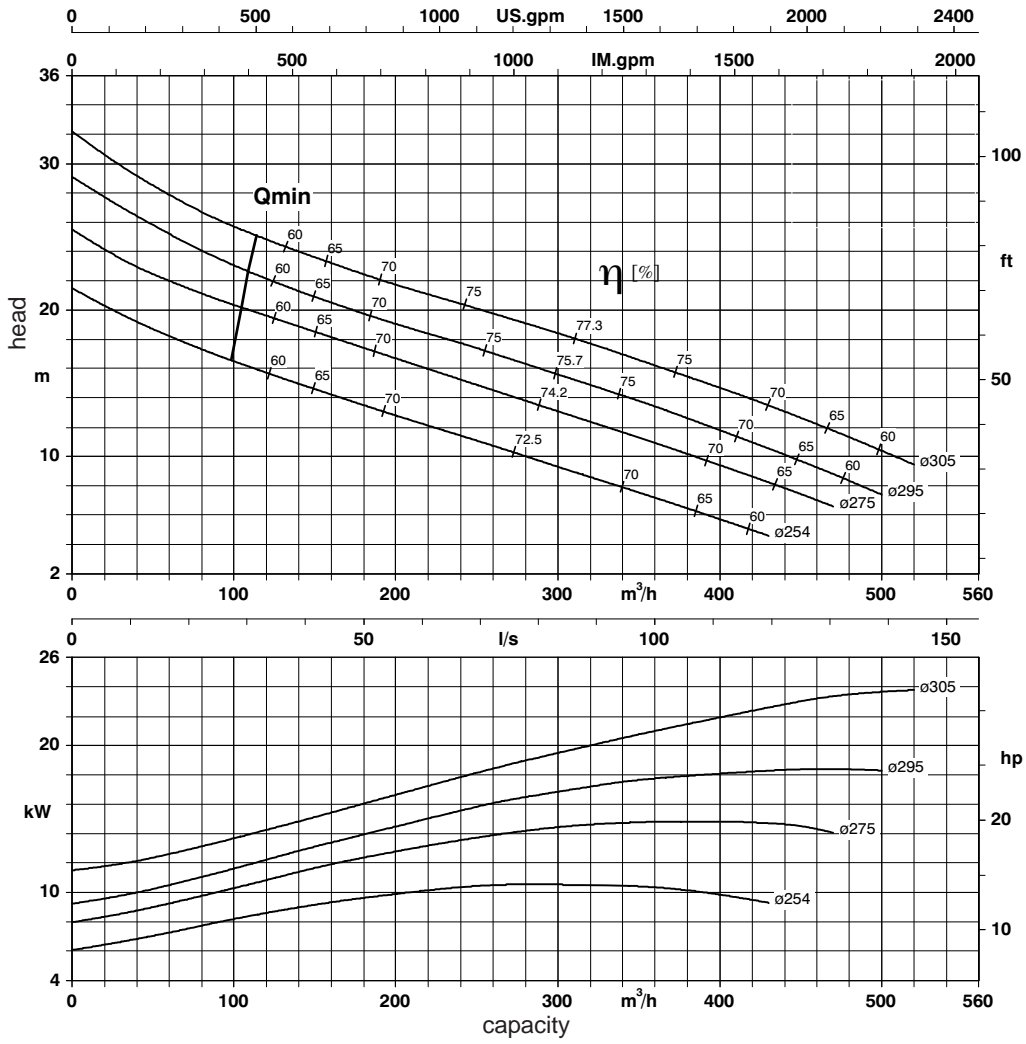

DRK 107

Connection [G]/[DN]	150
Pump casing	JL 1040
Impeller	JL 1040
Shaft	1.4021
Shaft seal pump side	SiC / SiC
Shaft seal motor side	Ca/SiC
Elastomer components	NBR
Connect Voltage [V]	3 * 400
Motor Voltage [V]	400/692
IP	68
Insulation Class	F
Thermal Motor Monitoring	Bi-metal
Electric connection	Cable
Length electric cable [m]	10
Free passage [mm]	76
Temp. Max pumped liquid [°C]	40
Pump control	No

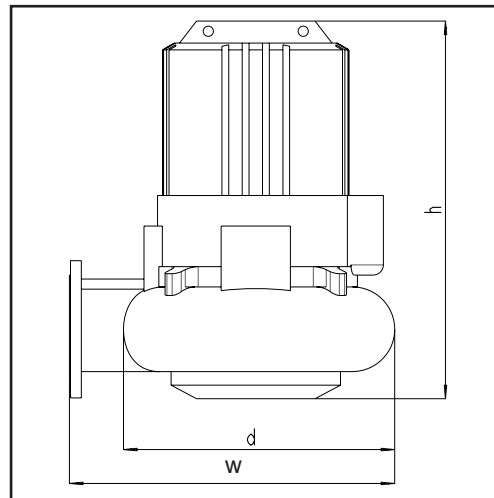

Pump type	P2 [kW]	Rated current [A]	Electric cable n x [mm ²]	Nom. speed [min ⁻¹]	Impeller diam. [mm]	h x b x d [mm]	Weight [kg]
107118-4 235	11,80	23,50	12*1,5	1465	235	740 x 640 x 535	146
107118-4 250	11,80	23,50	12*1,5	1465	250	740 x 640 x 535	146
107160-4 265	16,00	33,00	7*4+5*1,5	1465	265	740 x 640 x 535	256
107210-4 280	21,00	40,50	7*4+5*1,5	1435	280	880 x 640 x 535	325
107270-4 295	27,00	55,00	7*6+5*1,5	1455	295	850 x 640 x 535	343



DRK 145

Connection [G]/[DN]	200
Pump casing	JL 1040
Impeller	JL 1040
Shaft	1.4021
Shaft seal pump side	SiC/SiC
Shaft seal motor side	Ca/SiC
Elastomer components	NBR
Connect Voltage [V]	3 * 400
Motor Voltage [V]	400/692
IP	68
Insulation Class	F
Thermal Motor Monitoring	Bi-metal
Electric connection	Cable
Length electric cable [m]	10
Free passage [mm]	121
Pump control	No

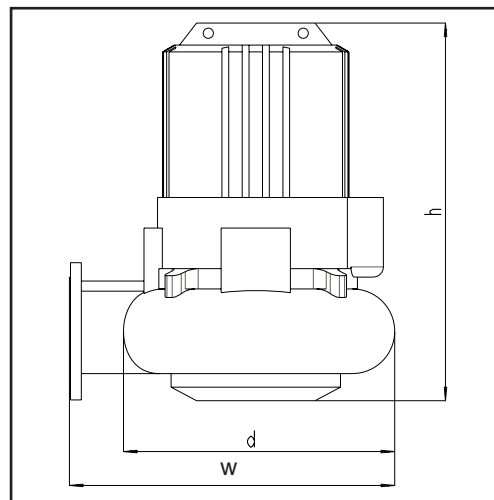

Pump type	P2 [kW]	Rated current [A]	Electric cable n x [mm2]	Nom. speed [min-1]	Impeller diam. [mm]	h x w x d [mm]	Temp. Max pumped liquid [°C]	Weight [kg]
145130-6 319	13,00	27,50	7*4+5*1,5	965	319	1045 x 840 x 640	60	480
145130-6 351	13,00	27,50	7*4+5*1,5	965	351	1045 x 840 x 640	60	480
145180-6 373	18,00	35,50	7*4+5*1,5	955	373	1045 x 840 x 640	40	480
145240-6 400	24,00	47,00	7*6+5*1,5	960	400	1020 x 840 x 640	40	505



DRK 145 50Hz

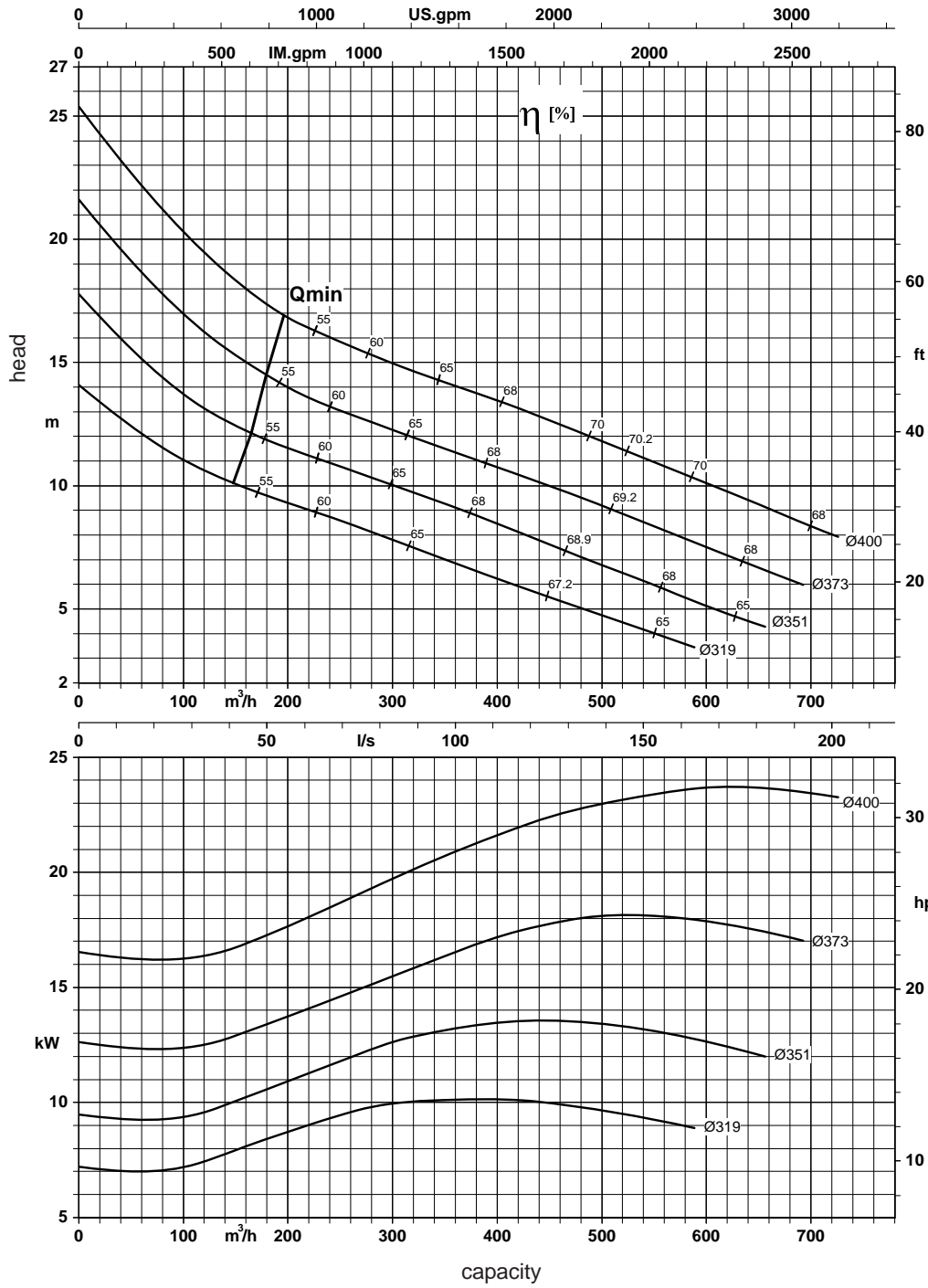

DRK 178

Connection [G]/[DN]	250
Pump casing	JL 1040
Impeller	JL 1040
Shaft	1.4021
Shaft seal pump side	SiC/SiC
Shaft seal motor side	Ca/SiC
Elastomer components	NBR
Connect Voltage [V]	3 * 400
Motor Voltage [V]	400/692
IP	68
Insulation Class	F
Thermal Motor Monitoring	Bi-metal
Electric connection	Cable
Length electric cable [m]	10
Free passage [mm]	85
Pump control	No

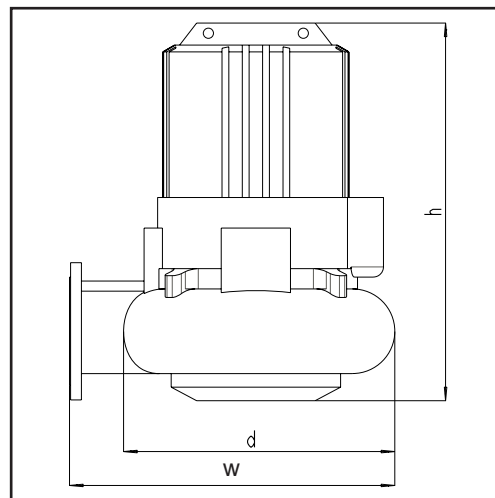

Pump type	P2 [kW]	Rated current [A]	Electric cable n x [mm ²]	Nom. speed [min ⁻¹]	Impeller diam. [mm]	h x b x d [mm]	Temp. Max pumped liquid [°C]	Weight [kg]
178130-6 300	13,00	27,50	7*4+5*1,5	965	300	970 x 990 x 735	60	555
178180-6 318	18,00	35,50	7*4+5*1,5	955	318	970 x 990 x 735	40	555
178240-6 340	24,00	47,00	7*6+5*1,5	960	340	945 x 990 x 735	40	580
178300-6 370	30,00	64,00	2*4*6+12*1,5	975	370	1105 x 990 x 735	40	710



DRK 178 50Hz

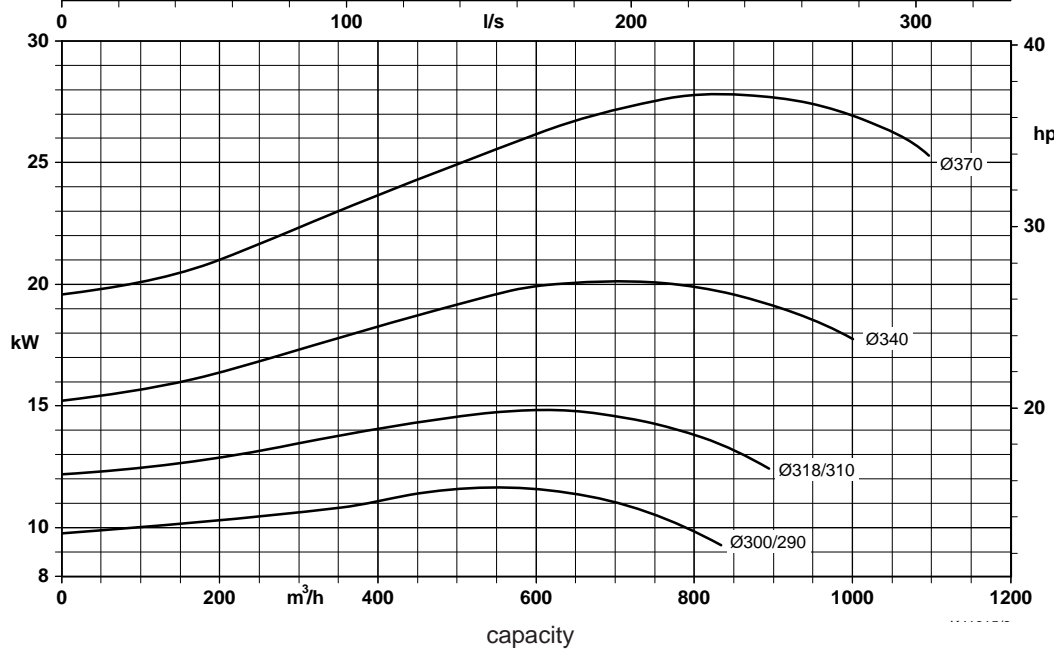
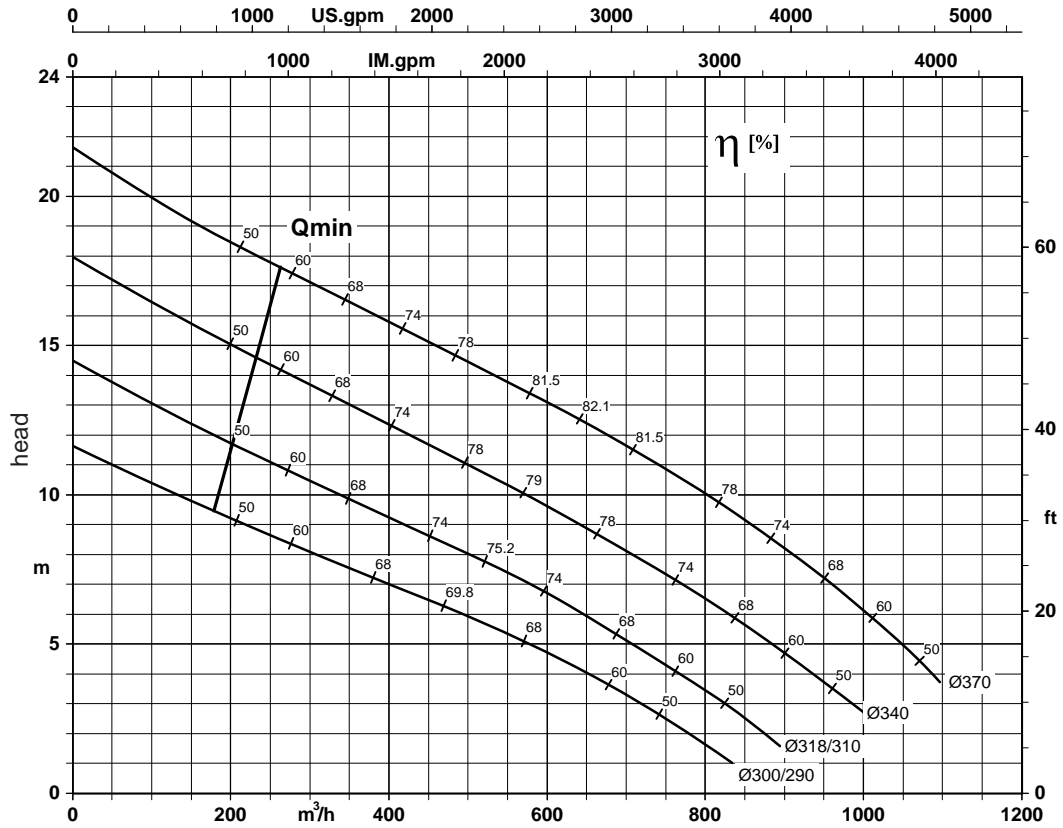

DRK 220

Connection [G]/[DN]	300
Pump casing	JL 1040
Impeller	JL 1040
Shaft	1.4021
Shaft seal pump side	SiC/SiC
Shaft seal motor side	Ca/SiC
Elastomer components	NBR
Connect Voltage [V]	3 * 400
Motor Voltage [V]	400/692
IP	68
Insulation Class	F
Thermal Motor Monitoring	Bi-metal
Electric cable n x [mm ²]	12*1,5
Electric connection	Cable
Length electric cable [m]	10
Free passage [mm]	135
h x w x d [mm]	1060 x 1050 x 850
Pump control	No

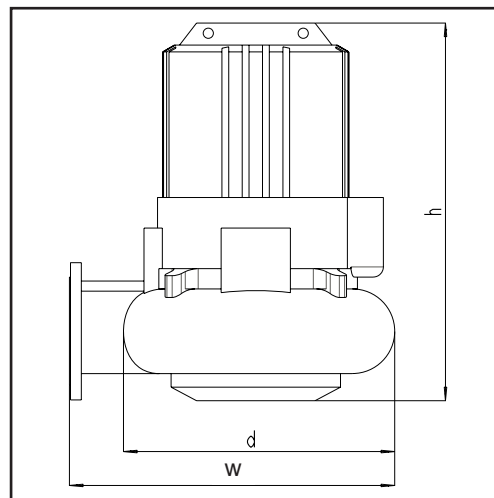

Pump type	P2 [kW]	Rated current [A]	Electric cable n x [mm ²]	Nom. speed [min ⁻¹]	Impeller diam. [mm]	Temp. Max pumped liquid [°C]	Weight [kg]
22070-8 367	7,00	16,50	12*1,5	725	367	60	735
220100-8 384	10,00	22,50	12*1,5	715	384	40	735
220160-8 398	16,00	36,00	7*4+5*1,5	730	398	40	755
220160-8 408	16,00	36,00	7*4+5*1,5	730	408	40	755



DRK 220 50Hz

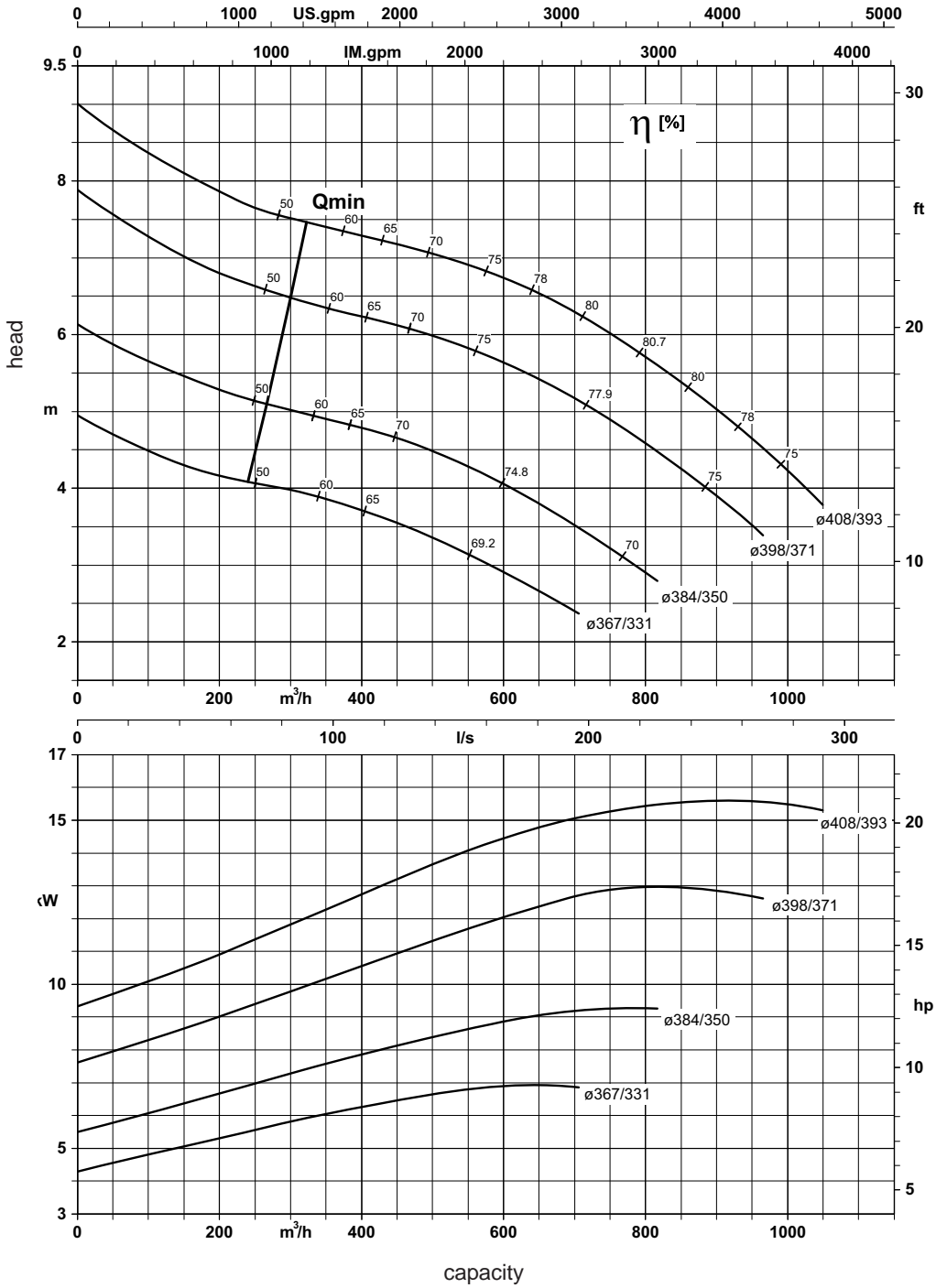

DRK 250

Connection [G]/[DN]	300
Pump casing	JL 1040
Impeller	JL 1040
Shaft	1.4021
Shaft seal pump side	SiC/SiC
Shaft seal motor side	Ca/SiC
Elastomer components	NBR
Connect Voltage [V]	3 * 400
Motor Voltage [V]	400/692
IP	68
Insulation Class	F
Thermal Motor Monitoring	Bi-metal
Electric connection	Cable
Length electric cable [m]	10
Free passage [mm]	100
Temp. Max pumped liquid [°C]	40
Pump control	No

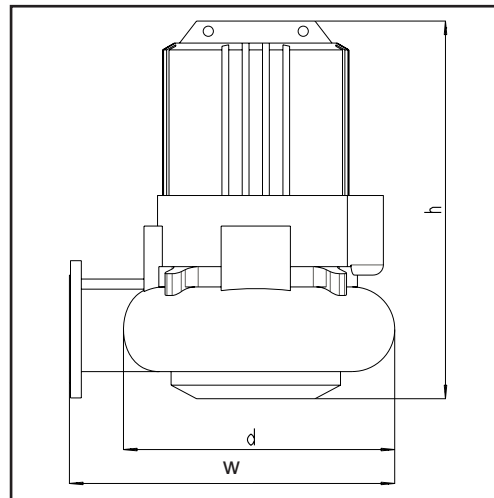

Pump type	P2 [kW]	Rated current [A]	Electric cable n x [mm ²]	Nom. speed [min ⁻¹]	Impeller diam. [mm]	h x w x d [mm]	Weight [kg]
250100-8 332	10,00	22,50	12*1,5	715	332	1060 x 1050 x 850	735
250160-8 355	16,00	36,00	7*4+5*1,5	730	355	1060 x 1050 x 850	755
250160-8 376	16,00	36,00	7*4+5*1,5	730	376	1060 x 1050 x 850	755
250200-8 390	20,00	44,00	7*6+5*1,5	705	390	1035 x 1050 x 850	775
250280-8 408	28,00	60,00	15	730	408	1200 x 1050 x 850	900



DRK 250 50Hz

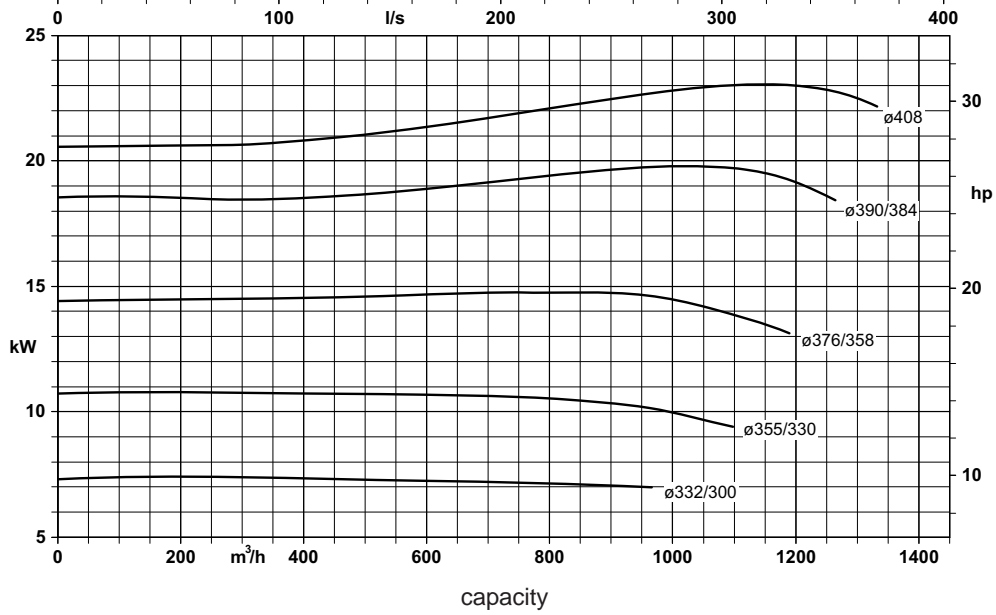
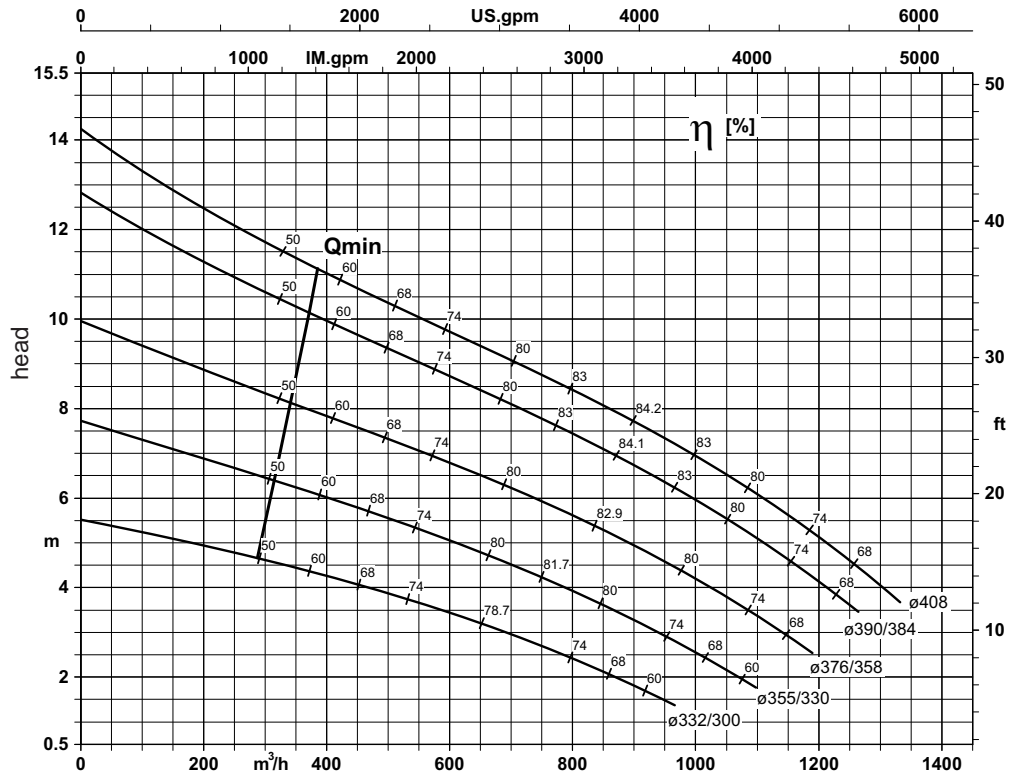

FEKA-UNIT C

Application

Automatic transport of domestic waste and sewage water

Capacity

50 m³/h

Head

8 mwc

Temperature range

Up to 35 °C continuously, 65 °C temporarily (5 minutes)

Reservoir

Synthetic material LLPDE

C1 (1 pump) :90 ltr. Gross

C2 (2 pumps) :150 ltr. Gross

Discharge connection DN 80

Control

Automatic level control by built-in float switch

Easy connection

The suction connection height of the Feka-Unit C is fit to the standard toilet connection; the unit can be installed at the same level as the connected toilet.

Other models

- 2 pumps (C2)
- other materials for more aggressive liquids
- equipped with cutter for smaller discharge connections
- other voltages and frequencies



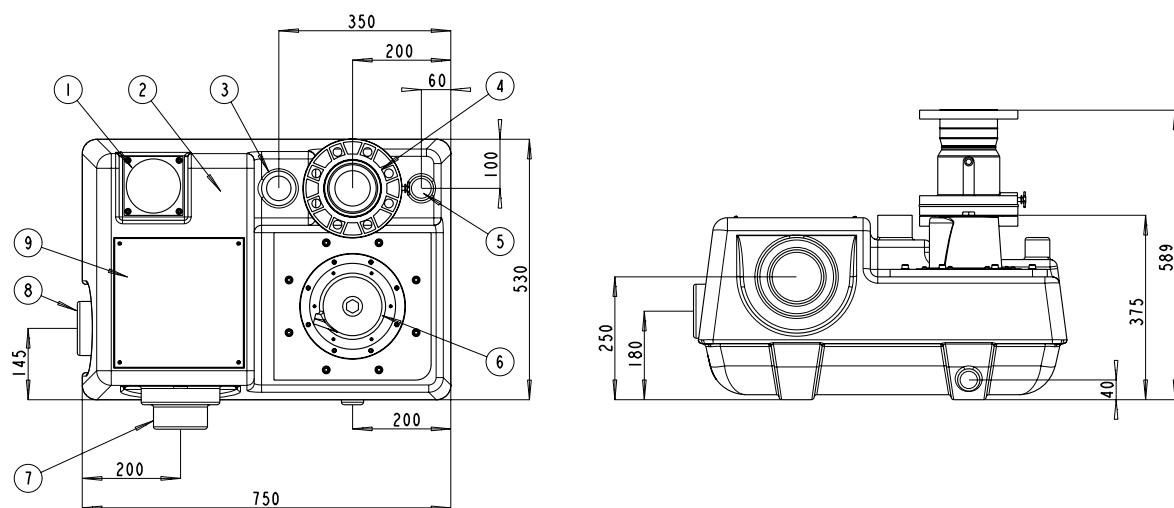
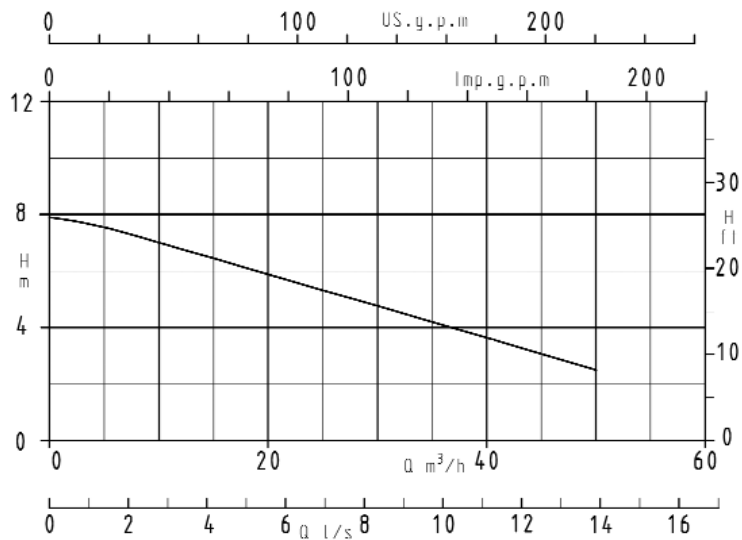

POS. NR.	NAME
1	Level control
2	Synthetic reservoir
3	Venting DN 70
4	Discharge connection NW80
5	Incoming drain connection DN50
6	Pump
7	Incoming drain connection DN100/150
8	Incoming drain connection DN100 for direct toilet connection
9	Inspection lid

ACCESSORIES

DP MT 30

Hydrostatic transmitter for optimum level control

DP-Pumps pressure transmitters are designed for level control in tanks, reservoirs, polders and containers in which submerged pressure transmitters are required. The working principle is based on measuring the hydrostatic pressure caused by the height of the fluid level. The ceramic measuring cell is built in a stainless steel housing.



DP MT 30

Stainless steel couplings

As a consequence of our expertise in stainless steel in clean water, we have developed a range of discharge couplings for application in sewage stations. Stainless steel is strong, hard-wearing and extremely resistant to H₂S.

Depending on the application and requirements, two types of couplings can be used. Both are suitable for various pump types and brands.

Header coupling

This stainless steel coupling is placed above the water surface. The pump hangs on to the coupling. This way, by lifting the pump, the sewage station is easy to inspect and clean. A continuous flow of the medium is guaranteed, as there are no obstacles on the reservoir bottom.



Header coupling

Guide bar coupling

This stainless steel coupling is placed on the bottom of the reservoir. This makes the installation of larger and heavier pumps possible. When pump inspection is required, the pump alone can be lifted. The special construction of the duckfoot guarantees a continuous flow of the medium.

Please feel free to contact DP-Pumps for more information on the products on this page.



Guide bar coupling





dp pumps

dp pumps
P.O. Box 28
2400 AA Alphen aan den Rijn
Holland

t +31 172 48 83 25
f +31 172 46 89 30

dp@dp-pumps.com
www.dp-pumps.com

